

ETSI EN 302 340 V2.1.1 (2016-05)

Reference

REN/SES-00393

Keywords

earth station, ESV, maritime, regulation, satellite

ETSI

650 Route des Lucioles
F-06921 Sophia Antipolis Cedex - FRANCE

Tel.: +33 4 92 94 42 00 Fax: +33 4 93 65 47 16

Siret N° 348 623 562 00017 - NAF 742 C
Association à but non lucratif enregistrée à la
Sous-Préfecture de Grasse (06) N° 7803/88

Important notice

The present document can be downloaded from:
<http://www.etsi.org/standards-search>

The present document may be made available in electronic versions and/or in print. The content of any electronic and/or print versions of the present document shall not be modified without the prior written authorization of ETSI. In case of any existing or perceived difference in contents between such versions and/or in print, the only prevailing document is the print of the Portable Document Format (PDF) version kept on a specific network drive within ETSI Secretariat.

Users of the present document should be aware that the document may be subject to revision or change of status. Information on the current status of this and other ETSI documents is available at
<https://portal.etsi.org/TB/ETSIDeliverableStatus.aspx>

If you find errors in the present document, please send your comment to one of the following services:
<https://portal.etsi.org/People/CommiteeSupportStaff.aspx>

Copyright Notification

No part may be reproduced or utilized in any form or by any means, electronic or mechanical, including photocopying and microfilm except as authorized by written permission of ETSI.

The content of the PDF version shall not be modified without the written authorization of ETSI.

The copyright and the foregoing restriction extend to reproduction in all media.

© European Telecommunications Standards Institute 2016.
All rights reserved.

DECT™, **PLUGTESTS™**, **UMTS™** and the ETSI logo are Trade Marks of ETSI registered for the benefit of its Members.
3GPP™ and **LTE™** are Trade Marks of ETSI registered for the benefit of its Members and of the 3GPP Organizational Partners.
GSM® and the GSM logo are Trade Marks registered and owned by the GSM Association.

Contents

Intellectual Property Rights	7
Foreword.....	7
Modal verbs terminology.....	7
Introduction	7
1 Scope	9
2 References	10
2.1 Normative references	10
2.2 Informative references.....	10
3 Definitions, symbols and abbreviations	11
3.1 Definitions	11
3.2 Symbols.....	13
3.3 Abbreviations	13
4 Technical requirements specifications	14
4.1 General	14
4.1.1 Environmental profile	14
4.1.2 Operational configurations	14
4.1.3 ESV states and radio states	14
4.2 Conformance requirements	15
4.2.1 Off-axis spurious radiation	15
4.2.1.1 Justification	15
4.2.1.2 Specification.....	16
4.2.1.3 Conformance tests.....	17
4.2.2 On-axis spurious radiation for ESV	17
4.2.2.1 Justification	17
4.2.2.2 Specification.....	17
4.2.2.2.1 "Carrier-on" radio state.....	17
4.2.2.2.2 "Carrier-off" and "Emissions disabled" radio states	18
4.2.2.3 Conformance tests.....	18
4.2.3 Maximum ESV emissions towards the horizon	18
4.2.3.1 Justification	18
4.2.3.2 Specification.....	18
4.2.3.2.1 Specification 1: Maximum e.i.r.p. spectral density towards the horizon	18
4.2.3.2.2 Specification 2: Maximum e.i.r.p. towards the horizon.....	18
4.2.3.3 Conformance tests.....	18
4.2.4 Off-axis e.i.r.p. emission density within the band.....	18
4.2.4.0 General	18
4.2.4.1 Justification	18
4.2.4.2 Specification.....	19
4.2.4.3 Conformance tests.....	20
4.2.5 Carrier suppression	20
4.2.5.1 Justification	20
4.2.5.2 Specification.....	20
4.2.5.3 Conformance tests.....	21
4.2.6 Antenna pointing and polarization alignment for ESVs	21
4.2.6.1 Justification	21
4.2.6.2 Specification.....	21
4.2.6.3 Conformance tests.....	22
4.2.7 Cessation of emissions of the ESV	22
4.2.7.1 Justification	22
4.2.7.2 Specification.....	22
4.2.7.2.1 Specification 1: Mode of cessation of emissions	22
4.2.7.2.2 Specification 2: Conditions under which the ESV shall cease emissions.....	22
4.2.7.2.3 Specification 3: Cessation of emissions	23
4.2.7.2.4 Specification 4: Fault conditions	23

4.2.7.3	Conformance tests	23
4.2.8	Identification of ESV	23
4.2.8.1	Justification	23
4.2.8.2	Specification.....	23
4.2.8.3	Conformance tests	23
4.2.9	Control and Monitoring Functions (CMFs)	24
4.2.9.1	CMF state diagram	24
4.2.9.2	Processor monitoring	25
4.2.9.2.1	Justification	25
4.2.9.2.2	Specification	25
4.2.9.2.3	Conformance tests	25
4.2.9.3	Transmit subsystem monitoring	25
4.2.9.3.1	Justification	25
4.2.9.3.2	Specification	25
4.2.9.3.3	Conformance tests	25
4.2.9.4	Power-on/Reset	25
4.2.9.4.1	Justification	25
4.2.9.4.2	Specification	25
4.2.9.4.3	Conformance tests	25
4.2.9.5	Control Channel (CC) and Response Channel (RC)	26
4.2.9.5.1	Justification	26
4.2.9.5.2	Specification	26
4.2.9.5.3	Conformance tests	26
4.2.9.6	Network control commands	27
4.2.9.6.1	Justification	27
4.2.9.6.2	Specification	27
4.2.9.6.3	Conformance test.....	27
4.2.9.7	Initial burst transmission	27
4.2.9.7.1	Justification	27
4.2.9.7.2	Specification	27
4.2.9.7.3	Conformance tests	28
4.2.10	Receive antenna off-axis gain pattern	28
4.2.10.1	Justification	28
4.2.10.2	Specification.....	28
4.2.10.3	Conformance tests	28
4.2.11	Blocking performance.....	28
4.2.11.1	Justification	28
4.2.11.2	Specification.....	28
4.2.11.3	Conformance tests	29
4.2.12	Adjacent Signal Selectivity.....	29
4.2.12.1	Justification	29
4.2.12.2	Specification.....	29
4.2.12.3	Conformance tests	29
5	Testing for compliance with technical requirements.....	29
5.1	Environmental conditions for testing	29
5.2	Essential radio test suites.....	30
6	Test methods for the complete ESV	30
6.1	General	30
6.2	Off-axis spurious radiation	31
6.2.0	General.....	31
6.2.1	Test method	31
6.2.1.a	General	31
6.2.1.0	Multi-carrier operation	31
6.2.1.1	Up to 2 000 MHz	32
6.2.1.1.1	Test site.....	32
6.2.1.1.2	Procedure.....	32
6.2.1.2	Above 2 000 MHz.....	32
6.2.1.2.0	General	32
6.2.1.2.1	Identification of the significant frequencies of spurious radiation	33
6.2.1.2.2	Measurement of radiated power levels of identified spurious radiation	33

6.2.1.2.3	Measurement of conducted spurious radiation at the antenna flange	35
6.3	On-axis spurious radiation.....	35
6.3.1	Test method	35
6.3.1.1	Test site	35
6.3.1.2	Method of measurement.....	36
6.3.1.2.1	General	36
6.3.1.2.2	Method of measurement at the antenna flange	36
6.3.1.2.3	Method of measurement with a test antenna	37
6.4	Maximum ESV emissions towards the horizon.....	38
6.4.1	Test method	38
6.4.1.1	Maximum e.i.r.p. towards the horizon	38
6.4.1.2	Maximum e.i.r.p. spectral density towards the horizon.....	38
6.5	Off-axis e.i.r.p. emission density within the band	38
6.5.0	General.....	38
6.5.1	Test method	39
6.5.1.1	General	39
6.5.1.2	Transmit output power density.....	39
6.5.1.2.1	General	39
6.5.1.2.2	Test site.....	39
6.5.1.2.3	Method of measurement	39
6.5.1.3	Antenna transmit gain	40
6.5.1.3.1	General	40
6.5.1.3.2	Test site.....	40
6.5.1.3.3	Method of measurement	41
6.5.1.4	Antenna transmit radiation patterns	42
6.5.1.4.1	General	42
6.5.1.4.2	Test site.....	42
6.5.1.4.3	Test arrangement	42
6.5.1.4.4	Co-polar radiation pattern-azimuth.....	42
6.5.1.4.5	Co-polar radiation pattern-elevation	43
6.5.1.4.6	Cross-polar radiation pattern-azimuth	43
6.5.1.4.7	Cross-polar radiation pattern-elevation	44
6.5.2	Computation of results.....	44
6.6	Carrier suppression.....	45
6.6.1	Test method	45
6.7	Antenna pointing for ESV	45
6.7.1	General.....	45
6.7.2	Test method	45
6.8	Antenna mechanical stability	46
6.8.1	Test method	46
6.9	Polarization angle alignment capability	46
6.9.1	Test method	46
6.10	Cessation of emissions of the ESV	47
6.10.1	Test arrangement	47
6.10.2	Test Method	48
6.10.2.1	Required documentation	48
6.10.2.2	Cessation of emissions from the "Transmission enabled" state	48
6.10.2.3	Cessation of emission from the "Transmission disabled" state	48
6.10.2.4	Cessation of emission from the "Initial Phase" state	48
6.10.2.4.1	EUTs transmitting initial bursts.....	48
6.10.2.4.2	EUTs not transmitting initial bursts.....	49
6.10.2.5	"Single action" means of cessation of emissions.....	49
6.10.2.6	Fault conditions	50
6.11	Identification of ESV	50
6.11.1	Test arrangement	50
6.11.2	Test method	50
6.12	Control and monitoring functions	50
6.12.0	General.....	50
6.12.1	Test arrangement	50
6.12.2	Processor monitoring- Test method	50
6.12.3	Transmit subsystem monitoring-Test method.....	51
6.12.4	Power-on/Reset-Test method.....	51

6.12.5	Control Channel and Response Channel -Test method.....	52
6.12.6	Network Control commands-Test method.....	53
6.12.7	Initial burst transmission-Test method.....	54
6.13	Receive antenna off-axis gain pattern	54
6.13.1	Test Method.....	54
6.13.1.1	Test site	54
6.13.1.2	Method of measurement.....	54
6.14	Blocking performance	55
6.14.1	Test method	55
6.15	Adjacent Signal Selectivity	56
6.15.1	Test method	56
Annex A (normative):	Relationship between the present document and the essential requirements of Directive 2014/53/EU	57
Annex B (normative):	Mechanical stability methodology	59
Annex C (informative):	Bibliography.....	61
History		62

Intellectual Property Rights

IPRs essential or potentially essential to the present document may have been declared to ETSI. The information pertaining to these essential IPRs, if any, is publicly available for **ETSI members and non-members**, and can be found in ETSI SR 000 314: "*Intellectual Property Rights (IPRs); Essential, or potentially Essential, IPRs notified to ETSI in respect of ETSI standards*", which is available from the ETSI Secretariat. Latest updates are available on the ETSI Web server (<https://ipr.etsi.org/>).

Pursuant to the ETSI IPR Policy, no investigation, including IPR searches, has been carried out by ETSI. No guarantee can be given as to the existence of other IPRs not referenced in ETSI SR 000 314 (or the updates on the ETSI Web server) which are, or may be, or may become, essential to the present document.

Foreword

This Harmonised European Standard (EN) has been produced by ETSI Technical Committee Satellite Earth Stations and Systems (SES).

The present document has been prepared under the Commission's standardisation request C(2015) 5376 final [i.5] to provide one voluntary means of conforming to the essential requirements of Directive 2014/53/EU on the harmonisation of the laws of the Member States relating to the making available on the market of radio equipment and repealing Directive 1999/5/EC [9].

Once the present document is cited in the Official Journal of the European Union under that Directive, compliance with the normative clauses of the present document given in table A.1 confers, within the limits of the scope of the present document, a presumption of conformity with the corresponding essential requirements of that Directive and associated EFTA regulations.

National transposition dates	
Date of adoption of this EN:	16 May 2016
Date of latest announcement of this EN (doa):	31 August 2016
Date of latest publication of new National Standard or endorsement of this EN (dop/e):	28 February 2017
Date of withdrawal of any conflicting National Standard (dow):	28 February 2018

Modal verbs terminology

In the present document "**shall**", "**shall not**", "**should**", "**should not**", "**may**", "**need not**", "**will**", "**will not**", "**can**" and "**cannot**" are to be interpreted as described in clause 3.2 of the [ETSI Drafting Rules](#) (Verbal forms for the expression of provisions).

"**must**" and "**must not**" are **NOT** allowed in ETSI deliverables except when used in direct citation.

Introduction

The present document is part of a set of standards developed by ETSI and is designed to fit in a modular structure to cover all radio equipment within the scope of the Directive 2014/53/EU [9]. The modular structure is shown in ETSI EG 201 399 [i.1].

Figure 1: Void

Remarks on the present document

The determination of the parameters of the user earth stations using a given geo-stationary satellite for the protection of the spectrum allocated to that satellite, is considered to be under the responsibility of the satellite operator or the satellite network operators.

The requirements have been selected to ensure an adequate level of compatibility with other radio services. The levels, however, do not cover extreme cases which may occur in any location but with a low probability of occurrence.

The present document is based on the application of ITU-R Resolution 902 (WRC-03) [i.2].

The present document may not cover those cases where a potential source of interference which is producing individually repeated transient phenomena or a continuous phenomenon is present, e.g. a radar or broadcast site in the near vicinity. In such a case it may be necessary to use special protection applied to either the source of interference, or the interfered part or both.

The present document does not contain any requirement, recommendation or information about the installation of the ESV.

All parts of the below-deck unit related to reception, processing and presentation of the received information except the control channel are not within the scope of the present document. The syntax of the control channel messages is outside the scope of the present document.

The present document is based upon the standard for environmental conditions for marine navigational equipment, CENELEC EN 60945 [7]. In addition, attention should be paid to clause 11.1 (Acoustic noise and signals), and clause 11.2 (Compass safe distance).

1 Scope

The present document applies to Earth Stations located on board Vessels (ESVs) which have the following characteristics:

- The ESV is comprised of all the equipment, electrical and mechanical, from the antenna itself to the interface with other communications equipment on board (usually referred to as the terrestrial interface).
- The ESV transmits in the frequency range from 14,00 GHz to 14,50 GHz allocated to the Fixed Satellite Services (FSS) (earth-to-space).
- The ESV receives in one or more frequencies within the range from 10,70 GHz to 12,75 GHz in the bands allocated to the Fixed Satellite Services (FSS) (space-to-earth), depending on the ITU Region where the ESV is located.
- The ESV uses linear polarization.
- The ESV operates through a geostationary satellite at least 2° to 3° away from any other geostationary satellite operating in the same frequency band and covering the same area.

NOTE 1: The satellite spacing is mainly equal to 3° in ITU Regions 1 and 3 and 2° in ITU Region 2.

The ESV transmits at elevations greater or equal to the minimum elevation angle declared by the applicant.

- The ESV antenna diameter is not smaller than 0,6 m.

NOTE 2: Operation within 125 km of non-CEPT countries with antenna diameter smaller than 1,2 m may be subject to specific agreement with concerned administrations as stated in ITU-R Resolution 902 (WRC-03).

- The ESV is designed for transmission and reception of radio-communications signals in accordance with any of the frequency bands specified above.
- The ESV is usually designed for unattended operation.
- The ESV is operating as part of a satellite network (e.g. star, mesh or point-to-point) used for the distribution and/or exchange of information between users.
- The ESV is controlled and monitored by a Network Control Facility (NCF). The NCF is outside the scope of the present document.

The present document applies to the ESV with its ancillary equipment and its various telecommunication ports, and when operated within the boundary limits of the operational environmental profile declared by the applicant and when installed as required by the applicant by declaration or in the user documentation.

The present document is intended to cover the provisions of Directive 2014/53/EU [9] (RE Directive) article 3.2, which states that "*... radio equipment shall be so constructed that it both effectively uses and supports the efficient use of radio spectrum in order to avoid harmful interference*".

The present document incorporates the technical limitations listed in annex 2 of ITU-R Resolution 902 (WRC-03) [i.2].

NOTE 3: According to ITU-R Resolution 902 (WRC-03), any transmission from ESVs within the 125 km minimum distance of each country where the ESV transmit frequency band is used by the Fixed Service will be subject to the prior agreement of the concerned administration(s) or to the relevant ECC Decision and may specify additional operational requirements.

In addition to the present document, other ENs that specify technical requirements in respect of essential requirements under other parts of article 3 of the Directive 2014/53 [9] (RE Directive) may apply to equipment within the scope of the present document.

NOTE 4: A list of such ENs is included on the web site <http://www.newapproach.org/>.

2 References

2.1 Normative references

References are either specific (identified by date of publication and/or edition number or version number) or non-specific. For specific references, only the cited version applies. For non-specific references, the latest version of the referenced document (including any amendments) applies.

Referenced documents which are not found to be publicly available in the expected location might be found at <http://docbox.etsi.org/Reference>.

NOTE: While any hyperlinks included in this clause were valid at the time of publication, ETSI cannot guarantee their long term validity.

The following referenced documents are necessary for the application of the present document.

- [1] Void.
- [2] Void.
- [3] Void.
- [4] Void.
- [5] CISPR 16-1 (2003): "Specification for radio disturbance and immunity measuring apparatus and methods".
- [6] CISPR 16-1-5 (2003): "Specification for radio disturbance and immunity measuring apparatus and methods; Part 1-5: Radio disturbance and immunity measuring apparatus - Antenna calibration test sites for 30 MHz to 1 000 MHz".
- [7] CENELEC EN 60945 (2002): "Maritime navigation and radiocommunication equipment and systems - General requirements - Methods of testing and required test results".
- [8] ITU-R Radio Regulations (2004).
- [9] Directive 2014/53/EU of the European Parliament and of the Council of 16 April 2014 on the harmonisation of the laws of the Member States relating to the making available on the market of radio equipment and repealing Directive 1999/5/EC (RE Directive).

2.2 Informative references

References are either specific (identified by date of publication and/or edition number or version number) or non-specific. For specific references, only the cited version applies. For non-specific references, the latest version of the referenced document (including any amendments) applies.

NOTE: While any hyperlinks included in this clause were valid at the time of publication, ETSI cannot guarantee their long term validity.

The following referenced documents are not necessary for the application of the present document but they assist the user with regard to a particular subject area.

- [i.1] ETSI EG 201 399: "Electromagnetic compatibility and Radio spectrum Matters (ERM); A guide to the production of Harmonized Standards for application under the Radio & Telecommunication Terminal Equipment Directive 1999/5/EC (R&TTE) and a first guide on the impact of the Radio Equipment Directive 2014/53/EU (RED) on Harmonized Standards".
- [i.2] ITU-R Resolution 902 (WRC-03): "Provisions relating to earth stations located on board vessels which operate in fixed-satellite service networks in the uplink bands 5 925-6 425 MHz and 14-14.5 GHz".
- [i.3] ETSI TR 102 215: "Electromagnetic compatibility and Radio spectrum Matters (ERM); Recommended approach, and possible limits for measurement uncertainty for the measurement of radiated electromagnetic fields above 1 GHz".

- [i.4] ETSI TR 102 375: "Satellite Earth Stations and Systems (SES); Guidelines for determining the parts of satellite earth station antenna radiation patterns concerned by the geostationary satellite orbit protection".
- [i.5] Commission Implementing Decision C(2015) 5376 final of 4.8.2015 on a standardisation request to the European Committee for Electrotechnical Standardisation and to the European Telecommunications Standards Institute as regards radio equipment in support of Directive 2014/53/EU of the European Parliament and of the Council.

3 Definitions, symbols and abbreviations

3.1 Definitions

For the purposes of the present document, the terms and definitions given in Directive 2014/53/EU [9] and the following apply:

above-deck unit: part of the ESV intended to be installed above deck, as declared by the applicant, or as indicated in the user documentation

The above-deck unit usually comprises the following main parts:

- a) The antenna sub-system which converts the incident radiation field into a guided wave and vice versa.
- b) The Low Noise Block (LNB) down converter, which is a device that amplifies, with very low internal noise, the received signals in the Radio Frequency (RF) band and converts them to intermediate frequencies.
- c) The up-converter and the power amplifier which convert from the intermediate frequency to RF and amplify the low level RF signals for transmission through the antenna subsystem.
- d) The stabilization and tracking subsystems that ensure pointing of the antenna main beam towards the satellite within the required accuracy.

NOTE: The installation equipment (means of attachment) is outside the scope of the present document. However, the antenna structures and other components directly mounted on the antenna and forming an integral part of it, are subject to the specifications of the present document.

ancillary equipment: equipment used in connection with an ESV is considered as ancillary if the three following conditions are met:

- a) the equipment is intended for use in conjunction with the ESV to provide additional operational and/or control features (e.g. to extend control to another position or location); and
- b) the equipment cannot be used on a stand alone basis, to provide user functions independently of the ESV; and
- c) the absence of the equipment does not inhibit the operation of the ESV.

applicant: manufacturer or his authorized representative within the European Community or the person responsible for placing the apparatus on the market

below-deck unit: part of the ESV equipment which is installed inside the vessel (i.e. below deck) and its connection cables with the above deck units

carrier-off radio state: radio state in which the ESV may transmit and does not transmit any carrier

NOTE 1: The phrase "the ESV may transmit" means that all the conditions for transmission are satisfied (e.g. in a state where transmissions are permitted, no failure detected, and the ESV is correctly pointed towards the satellite).

NOTE 2: The existence of a "Carrier-off" radio state depends on the system of transmission used. For ESVs designed for continuous transmission mode there may be no "Carrier-off" state.

carrier-on radio state: radio state in which the ESV may transmit and transmits a carrier

Control Channel (CC): channel or channels by which ESVs receive control information from the NCF

EIRP_{max}: maximum e.i.r.p. capability of the ESV as declared by the applicant

EIRP_{nom}:

- (i) either EIRP_{max};
- (ii) or, when uplink power control is implemented, the maximum required e.i.r.p. of the ESV under clear sky condition as declared by the applicant.

emissions disabled radio state: radio state in which the ESV does not emit

NOTE: Examples of cases where the ESV is in this radio state: before system monitoring pass, before the control channel is received, when a failure is detected, when an ESV is commanded to disable, and when the ESV in a location requiring cessation of emissions.

environmental profile: range of environmental conditions under which equipment within the scope of ETSI EN 302 340 (the present document) is required to comply with the provisions of ETSI EN 302 340

external control channel: control channel which is either (i) carried by the ESV network via the same or another satellite, but not within the internal protocol of the ESV system, or (ii) carried by any other radio communication system

external response channel: response channel which is either (i) carried by the ESV network via the same or another satellite, but not within the internal protocol of the ESV system, or (ii) carried by any other radio communication system

integral antenna: antenna which may not be removed during the tests according to the applicant's statement

internal control channel: control channel which is carried by the ESV network via the same satellite as used for transmission of user data and within the internal protocol structure of the ESV system

internal response channel: response channel which is carried by the ESV network via the same satellite as used for transmission of user data and within the internal protocol structure of the ESV system

network: any network configuration including star, mesh and point-to-point configurations

Network Control Facility (NCF): set of functional entities that, at system level, monitor and control the correct operation of all ESVs in a network

nominal antenna diameter: antenna diameter declared by the manufacturer that is a parameter in performance characteristics and that allows reference to a certain performance

NOTE: An antenna with circular aperture of diameter equal to the nominal diameter does typically have the performance specified.

Network operators might request antennas of a certain diameter. Then an antenna that is compliant with the requirement for nominal antenna diameter equal to the requested antenna diameter can be used. Manufacturers can mark their equipment with antenna diameters used in the requirements during compliance test.

nominated bandwidth: bandwidth of the ESV radio frequency transmission nominated by the applicant. The nominated bandwidth is centred on the transmit frequency and does not exceed 5 times the occupied bandwidth

NOTE: The nominated bandwidth is wide enough to encompass all spectral elements of the transmission which have a level greater than the specified spurious radiation limits. The nominated bandwidth is wide enough to take account of the transmit carrier frequency stability. This definition is chosen to allow flexibility regarding adjacent channel interference levels which will be taken into account by operational procedures depending on the exact transponder carrier assignment situation.

off-axis angle: angle between the direction of the axis of the antenna main beam and the considered direction

removable antenna: antenna which may be removed during the tests according to the applicant's statement

Response Channel (RC): channel by which ESV transmit monitoring information to the NCF

spurious radiation: any radiation outside the nominated bandwidth

Transmission disabled state: ESV is in this state when it is not authorized by the NCF to transmit

Transmission enabled state: ESV is in this state when it is authorized by the NCF to transmit

Wanted signal occupied bandwidth (BW):

- for a digital modulation scheme: the width of the signal spectrum 10 dB below the maximum in-band density;
- for an analogue modulation scheme: the width of a frequency band such that, below the lower and above the upper frequency limits, the mean power emitted is equal to 0,5 % of the total mean power of the emission.

3.2 Symbols

For the purposes of the present document, the following symbols apply:

dBc	Ratio expressed in decibels relative to the e.i.r.p. of the unmodulated carrier
dB _i	Ratio of an antenna gain to the gain of an isotropic antenna, expressed in decibels
dB _{sd}	Ratio expressed in decibels relative to the spectral density
dBW	Ratio of a power to 1 watt, expressed in decibels
dB _{pW}	Ratio of a power to 1 pico watt, expressed in decibels
dB _{μV/m}	Ratio of an electric field to 1 μV/m, expressed in decibels (20 log(electric field / 1 μV/m))

3.3 Abbreviations

For the purposes of the present document, the following abbreviations apply:

BW	Wanted signal occupied Bandwidth
BDU	Below Deck Unit
CC	Control Channel
CCF	Control Channel reception Failure CCR Control Channel correctly Received
CENR	Cessation of Emissions Not Requested
CEPT	Conf érence Europ éenne des Postes et T élécommunications (European Conference of Postal and Telecommunications Administrations)
CER	Cessation of Emissions Requested
CISPR	Comité International Spécial des Perturbations Radio électriques (International Special Committee on Radio Interference)
CMF	Control and Monitoring Functions
e.i.r.p.	equivalent isotropically radiated power
ECC	Electronic Communications Committee (of CEPT)
EMC	Electro-Magnetic Compatibility
EN	European Standard
ESV	Earth Station on board a Vessel
EUT	Equipment Under Test
FEC	Forward Error Correction
FS	Fixed Service
FSS	Fixed Satellite Service
GEUT	Gain of EUT
GSO	Geostationary Satellites Orbit
HPA	High Power Amplifier
IPR	Intellectual Property Rights
ITU	International Telecommunications Union
ITU-R	Internail Telecommunication Union - Radiocommunication Sector
LNB	Low Noise Block
LO	Local Oscillator
LV	Low Voltage
NCF	Network Control Facility
R&TTE	Radio and Telecommunications Terminal Equipment
RC	Response Channel
RE	Radio Equipment
RED	RE Directive
RF	Radio Frequency
SMF	System Monitoring Fail
SMP	System Monitoring Pass

STE	Special Test Equipment
TxD	Transmission Disable command
TxE	Transmission Enable command
WGSE	Working Group Spectrum Engineering
WRC	ITU World Radio Conference
XPD	Cross Polar Discrimination
XPDESV	Maximum Equivalent Cross Polar Discrimination (XPD) of the ESV

4 Technical requirements specifications

4.1 General

4.1.1 Environmental profile

Before carrying out any other tests specified in the present document, survivability testing of the ESV shall be conducted under the following clauses CENELEC EN 60945 [7]:

- Clause 8.1 General
- Clause 8.3 Damp heat
- Clause 8.7 Vibration

The components of the ESV may be subject to different operational environmental conditions and shall maintain their performance in accordance with the present document under all environmental circumstances for the environmental classes applicable to them as defined in CENELEC EN 60945 [7]. Specifically, the operational environmental conditions for:

- "protected" class shall apply to the below deck equipment; and
- "exposed" class shall apply to the above deck equipment.

4.1.2 Operational configurations

Under operational conditions an ESV may dynamically change the occupied bandwidth and other transmission parameters (e.g. FEC, modulation, symbol rate) of the transmitted signal. For each occupied bandwidth an $EIRP_{max}$, an $EIRP_{nom}$ and a nominated bandwidth shall be declared by the applicant. The following specifications apply to the ESV for each occupied bandwidth and other transmission parameters.

4.1.3 ESV states and radio states

For the purpose of the present document the following four ESV states are defined, without presuming the effective implementation of the ESV state machine:

- "Non valid";
- "Initial phase";
- "Transmission disabled"; and
- "Transmission enabled".

The four ESV states are represented on figure 2 and are used in clause 4.2.9 for the specification of the Control and Monitoring Functions (CMFs).

In the "Non-valid" state and in the "Transmission disabled" state the ESV is not allowed to transmit. In the "Transmission-enabled" state the ESV is allowed to transmit. In the "Initial phase" state the ESV is only allowed to transmit initial bursts or is waiting for a transmit enable/disable command.

The "Initial phase" is divided into three radio states:

- "Initial phase-0" until the first initial burst is transmitted or when no initial bursts are transmitted;

- "Initial phase-1" during the transmission of the initial bursts;
- "Initial phase-2" between initial bursts.

NOTE: ESVs which do not transmit initial bursts have no "Initial phase-1" state and no "Initial phase-2" state.

The ESV "may transmit" when all the conditions for transmission are satisfied (e.g. in a state where transmissions are permitted, no failure detected, correctly pointed towards the satellite and there is no requirement for cessation of emissions).

The following radio states of the ESV are defined:

- "Emissions disabled" when the ESV does not transmit any carrier;
- "Carrier-off" when the ESV may transmit and does not transmit any carrier;
- "Carrier-on" when the ESV may transmit and transmits a carrier.

Table 1 gives the only possible combinations of the ESV states and radio states which shall apply, with some examples of associated events.

When the ESV transmits several carriers having different frequencies, an ESV state machine as described above may be associated with each carrier or each set of carriers.

Table 1: ESV states and radio states of the ESV

ESV states	Radio states	Examples of events
"Non valid"	"Emissions disabled"	After-power on, or After any failure, or During the checking phase
"Initial phase"		When waiting for a transmission enable or disable command from the NCF
"Initial phase-0"	"Emissions disabled"	Before the first initial burst transmissions; or In locations where no transmission is allowed
"Initial phase-1"	"Carrier-on"	During the transmission of each initial burst, and the pointing is correct
"Initial phase-2"	"Carrier-off"	Between initial bursts, or When the pointing threshold is exceeded
"Transmission enabled"	"Carrier-off"	When no carrier is transmitted, or When the pointing threshold is exceeded
	"Carrier-on"	During transmission of carrier(s), and the pointing is correct
"Transmission disabled"	"Emissions disabled"	When a disable command from the NCF has been received and waiting for a transmission enable command from the NCF, or in locations where no transmission is allowed

4.2 Conformance requirements

4.2.1 Off-axis spurious radiation

4.2.1.1 Justification

To limit the level of interference to terrestrial and satellite radio services.

The limits below 2 GHz are those specified in CENELEC EN 60945 [7] for marine navigational equipment, i.e. for the maritime environment.

4.2.1.2 Specification

The following specifications apply to the ESV transmitting at e.i.r.p. values up to and including $EIRP_{max}$.

- 1) The electric field strength level of any radiation from the ESV in the frequency range from 30 MHz to 2 GHz shall not exceed the limits specified in table 2.

Table 2: Limits of radiated electric field strength at a measuring distance of 3 m

Frequency range	Limit (Quasi Peak)	Limit (Peak)	Measurement bandwidth
30 MHz to 1 GHz	54 dB μ V/m	No limit applies	100 kHz to 120 kHz
1 GHz to 2 GHz	No limit applies	54 dB μ V/m	100 kHz to 120 kHz
156 MHz to 165 MHz	24 dB μ V/m	30 dB μ V/m	9 kHz to 10 kHz

NOTE: The CENELEC EN 60945 [7] limits below 30 MHz are not relevant for ESVs radiating in the band 14,0 GHz to 14,5 GHz.

The Peak and Quasi Peak detectors shall be in accordance with CISPR 16-1 [5].

- 2) When the ESV is in the "Emissions disabled" radio state, the off-axis spurious Equivalent Isotropically Radiated Power (e.i.r.p.) from the ESV, in any 100 kHz band, shall not exceed the limits in table 3, for all off-axis angles greater than 7 ° or greater than the minimum elevation angle declared by the applicant, whichever is lower.

Table 3: Limits of spurious e.i.r.p. - "Emissions disabled" radio state

Frequency band	e.i.r.p. limit	Measurement bandwidth
2,0 GHz to 10,7 GHz	48 dBpW	100 kHz
10,7 GHz to 21,2 GHz	54 dBpW	100 kHz
21,2 GHz to 40,0 GHz	60 dBpW	100 kHz

The lower limits shall apply at the transition frequency.

- 3) This specification applies outside the nominated bandwidth. In the "Carrier-on" and "Carrier-off" radio states, the off-axis spurious e.i.r.p. density from the ESV, shall not exceed the limits in table 4, for all off-axis angles greater than 7 ° or greater than the minimum elevation angle declared by the applicant, whichever is lower.

Table 4: Limits of spurious e.i.r.p. - "Carrier-on" and "Carrier-off" radio states

Frequency band	e.i.r.p. limit	Measurement bandwidth	Remarks
2,0 GHz to 3,4 GHz	49 dBpW	100 kHz	
3,4 GHz to 10,7 GHz	55 dBpW	100 kHz	
10,7 GHz to 13,75 GHz	61 dBpW	100 kHz	
13,75 GHz to 14,0 GHz	95 dBpW	10 MHz	See note 1
14,00 GHz to 14,25 GHz			See note 2
14,250 GHz to 14,75 GHz	95 dBpW	10 MHz	See note 1
14,75 GHz to 21,2 GHz	61 dBpW	100 kHz	
21,2 GHz to 40,0 GHz	67 dBpW	100 kHz	

NOTE 1: This limit may be exceeded in a frequency band which shall not exceed 50 MHz, centred on the carrier frequency, provided that the on-axis e.i.r.p. density at the considered frequency is 50 dB below the maximum on-axis e.i.r.p. density of the signal (within the nominated bandwidth) expressed in dBW/100 kHz.

NOTE 2: A limit may be required in regions outside CEPT where FS systems have an allocation and are operating in the band 14,00 GHz to 14,25 GHz. This requirement is outside the scope of the present document.

The lower limits shall apply at the transition frequency.

In the frequency band 28,0 GHz to 29,0 GHz, for any 20 MHz band within which one or more spurious signals exceeding the above limit of 67 dBpW/100 kHz are present, then the power of each of those spurious signals exceeding the limit shall be added in watts, and the sum shall not exceed 78 dBpW.

For ESVs designed to transmit simultaneously several carriers (multicarrier operation), the above limits apply to any combination of carriers declared by the applicant and outside the shortest bandwidth encompassing the nominated bandwidths of the carriers.

Each combination of carriers shall be characterized by the carriers' centre frequencies and characteristics, the maximum value of the total on-axis e.i.r.p. of the carriers and the relative levels of the carriers (in dBs) at the input or output of the HPA or antenna.

- 4) These limits are applicable to the complete ESV equipment, comprising the equipment units below and above deck including cabling between the units.

4.2.1.3 Conformance tests

Conformance tests shall be carried out in accordance with clause 6.2.

4.2.2 On-axis spurious radiation for ESV

4.2.2.1 Justification

To limit the level of interference to satellite radio services.

4.2.2.2 Specification

4.2.2.2.1 "Carrier-on" radio state

The following specification applies to the ESV transmitting at e.i.r.p. values up to $EIRP_{nom}$. For e.i.r.p. above $EIRP_{nom}$ (when uplink power control is implemented) the limits below may be exceeded by the difference in dB between the current e.i.r.p. and $EIRP_{nom}$.

In the 14,0 GHz to 14,5 GHz band the e.i.r.p. spectral density of the spurious radiation and outside a bandwidth of 5 times the occupied bandwidth centred on the carrier centre frequency shall not exceed $4 - K$ dBW in any 100 kHz band.

The e.i.r.p. spectral density of the spurious radiation outside the nominated bandwidth and within a bandwidth of 5 times the occupied bandwidth centred on the carrier centre frequency, shall not exceed $18 - K$ dBW in any 100 kHz band.

Where K is the factor that accounts for a reduction on the on-axis spurious radiation level in case of multiple ESVs transmitting towards the same satellite on the same frequency and polarization; the value of K is given by one the following cases:

- 1) For the case where only one ESV transmits at any one time on a given carrier frequency, the value of K is 0.
- 2) For the case where several ESVs are expected to transmit simultaneously on a given carrier frequency at the same e.i.r.p. then $K = 10 \log(N)$ where N is the maximum number of these ESVs. The value of N shall not be exceeded for more than 0,01 % of the time. The value of N and the operational conditions of the system shall be declared by the applicant.
- 3) For the case where several ESVs are expected to transmit simultaneously on a given carrier frequency at different e.i.r.p. levels then $K = -10 \log(EIRP/EIRP_{Aggregate})$, where:
 - e.i.r.p. is the on-axis e.i.r.p. (Watts) of the ESV within the nominated bandwidth; and
 - $EIRP_{Aggregate}$ is the maximum on-axis aggregate e.i.r.p. (Watts) within the nominated bandwidth of the ESV system towards the satellite;
 - $EIRP_{Aggregate}$ shall not be exceeded for more than 0,01 % of the time.

The value of $EIRP_{Aggregate}$ and the operational conditions of the ESV network shall be declared by the applicant.

NOTE 1: The on-axis spurious radiations, outside the 14,0 GHz to 14,5 GHz band, are indirectly limited by clause 4.2.1.2 Consequently no specification is needed.

NOTE 2: Intermodulation limits inside the band 14,0 GHz to 14,5 GHz are to be determined by system design and are subject to satellite operator specifications.

For ESVs designed to transmit several carriers on different frequencies simultaneously (multicarrier operation), the above limits only apply to each individual carrier when transmitted alone.

4.2.2.2.2 "Carrier-off" and "Emissions disabled" radio states

In the 14,0 GHz to 14,5 GHz band the e.i.r.p. spectral density of the spurious radiation outside the nominated bandwidth shall not exceed -21 dBW in any 100 kHz band.

4.2.2.3 Conformance tests

Conformance tests shall be carried out in accordance with clause 6.3.

4.2.3 Maximum ESV emissions towards the horizon

4.2.3.1 Justification

Protection of terrestrial services.

4.2.3.2 Specification

4.2.3.2.1 Specification 1: Maximum e.i.r.p. spectral density towards the horizon

The ESV e.i.r.p. spectral density towards the horizon, within the frequency band 14,0 GHz to 14,5 GHz, shall not exceed 12,5 dBW in any 1 MHz frequency band as specified in ITU-R Resolution 902 (WRC-03) [i.2], for all operational elevations angles of the antenna main beam axis.

The applicant shall declare the range of operational elevations angles of the antenna main beam axis of the ESV.

4.2.3.2.2 Specification 2: Maximum e.i.r.p. towards the horizon

The ESV e.i.r.p. towards any horizontal direction, within the frequency band 14,0 GHz to 14,5 GHz, shall not exceed 16,3 dBW as specified in ITU-R Resolution 902 (WRC-03) [i.2], for all operational elevations angles of the antenna main beam axis.

The applicant shall declare the range of operational elevations angles of the antenna main beam axis of the ESV.

4.2.3.3 Conformance tests

Conformance tests shall be carried out in accordance with clause 6.4.

4.2.4 Off-axis e.i.r.p. emission density within the band

4.2.4.0 General

This clause deals with the off-axis e.i.r.p. emission density (co-polar and cross-polar) within the band 14,0 GHz to 14,5 GHz.

4.2.4.1 Justification

Protection of other satellite (uplink) systems.

4.2.4.2 Specification

The following specifications apply to the ESV transmitting at e.i.r.p. values up to $EIRP_{max}$.

The maximum e.i.r.p. in any 40 kHz band within the nominated bandwidth of the co-polarized component in any direction φ degrees from the antenna main beam axis shall not exceed the following limits:

$$\begin{aligned} 33 - 25 \log(\varphi + \delta\varphi) - H \text{ dBW} & \text{ for } \varphi_{min} \leq \varphi + \delta\varphi \leq 7,0^\circ; \\ +12 - H \text{ dBW} & \text{ for } 7,0^\circ < \varphi + \delta\varphi \leq 9,2^\circ; \\ 36 - 25 \log(\varphi + \delta\varphi) - H \text{ dBW} & \text{ for } 9,2^\circ < \varphi + \delta\varphi \leq 48^\circ; \\ -6 - H \text{ dBW} & \text{ for } \varphi + \delta\varphi > 48^\circ; \end{aligned}$$

where:

- φ is the angle, in degrees, between the main beam axis and the direction considered; and
- $\delta\varphi$ is the pointing error threshold, in degrees, **relative to the line between the ESV and the satellite with which it is operating**, as declared by the applicant (see clause 4.2.6.2).

For ESVs designed to transmit always at $EIRP_{max}$, H (in dB) is the maximum number of ESVs transmitting towards the same satellite on the same frequency and polarization which may transmit at $EIRP_{max}$ in the same 40 kHz band as declared by the manufacturer.

For ESVs designed to operate in an FSS network where the e.i.r.p. of each ESV is determined by the NCF and where the NCF is in charge of the compliance of the aggregate e.i.r.p. density with the above mask, H is the margin as declared by the manufacturer for compliance with the mask, when the ESV is transmitting at $EIRP_{max}$. In the case where the NCF uses the antenna pattern or the off-axis $EIRP_{sd}$ the manufacturer shall declare the applicable pattern, the value of H shall be set to 0 dB and the ESV e.i.r.p. density shall not exceed the e.i.r.p. density corresponding to the declared pattern. This margin H or this pattern may be a function of the position of the ESV relative to the GSO arc (e.g. in the case of active antennas).

The applicant shall declare the minimum satellite separation, ΔL , for which the equipment is designed. Where ΔL shall be a value from $2,0^\circ$ to $3,0^\circ$. With this, φ_{min} as used in the above equation is equal to $2,0^\circ$ or $\Delta L - 0,2^\circ$, whichever is greater.

NOTE 1: The minimum satellite spacing, ΔL , is mainly equal to 3° in ITU Regions 1 & 3 and 2° in ITU Region 2.

For $\varphi > 70^\circ$ the values given above may be increased to $4 - H$ dBW over the range of angles for which the particular feed system may give rise to relatively high levels of spillover.

In addition the maximum e.i.r.p. in any 40 kHz band within the nominated bandwidth of the cross-polarized component in any direction φ degrees from the antenna main beam axis shall not exceed the following limits:

$$\begin{aligned} 23 - 25 \log(\varphi + \delta\varphi) - H \text{ dBW} & \text{ for } \varphi_{min} \leq \varphi + \delta\varphi \leq 7,0^\circ; \\ +2 - H \text{ dBW} & \text{ for } 7,0^\circ < \varphi + \delta\varphi \leq 9,2^\circ; \end{aligned}$$

where φ , φ_{min} and H are as defined above.

For non-continuous transmission, the above limits may not apply for a specific portion of each burst as declared by the applicant. This excluded portion shall not exceed 50 μ sec or 10 % of the burst, whichever is the smaller.

The excluded portion shall have characteristics similar to the remaining part of the burst:

- same symbol rate and modulation; and
- same or lower maximum amplitude.

In the case of ESVs employing uplink power control, the above limits, for co-polar and cross-polar components, shall apply under clear-sky conditions and these limits include all additional margins above the minimum clear-sky level necessary for the implementations of uplink power control. For ESVs implementing uplink power control, the above limits may be exceeded by up to A dB during fade conditions, where A is the attenuation of the transmit signal relative to clear sky conditions.

The uplink power control shall be subject to following additional requirement:

- The value of A shall not exceed 10 dB.

NOTE 2: The satellite operator may require lower off-axis e.i.r.p. limits in compliance with FSS Intersystem Coordination Agreements. In other cases, operation of the ESV within national waters, off-axis e.i.r.p. emissions are subject to compliance with national regulations and the relevant FSS intersystem coordination agreements.

Any antenna off-axis direction may be defined by a pair of values (α, ϕ) where ϕ is the off-axis angle of that direction with the antenna main beam axis and α is the angle of the plane defined by that direction and the antenna main beam axis with any arbitrary plane containing the antenna main beam axis.

The range of values of ϕ and α is from $\phi_{\min} - \delta\phi$ to 180° for ϕ , and from -180° to $+180^\circ$ for α .

The above limits only apply to any off-axis direction (α, ϕ) within $\pm 3^\circ$ of the visible part of the GSO. The concerned directions shall be any direction within the (α, ϕ) domain unless it can be demonstrated by documentary evidence that only a limited subset of the (α, ϕ) domain is concerned.

The determination of the (α, ϕ) subset shall take into account the operational conditions for which the ESV is designed, as declared by the applicant or indicated within the user documentation. These conditions shall include:

- the range of latitudes of the ESV;
- the minimum elevation pointing angle;
- the type of antenna mount (e.g. with azimuth and elevation axes or equatorial);
- the maximum static and dynamic alignment errors of the antenna mount axes;
- the maximum static and dynamic alignment errors of the antenna major axis with respect to the GSO arc;
- the range of adjustment for the major axis of the antenna for antennas with asymmetric main beam;
- the direction of the electric field radiated by the satellite with respect to the Earth's axis, when the electric field is used for the antenna alignment.

The alignment errors shall not exceed the declared maximum values when applying the alignment method declared by the applicant or indicated within the user documentation.

NOTE 3: ETSI TR 102 375 [i.4] gives guidance for the determination of the concerned subset within the (α, ϕ) domain.

4.2.4.3 Conformance tests

Conformance tests shall be carried out in accordance with clause 6.5.1 with the results being computed in accordance with clause 6.5.2.

4.2.5 Carrier suppression

4.2.5.1 Justification

To allow for the satisfactory suppression of transmissions of the ESV by the NCF, under any fault condition and under any cessation of emissions condition.

4.2.5.2 Specification

In the "Carrier-off" and in the "Emissions disabled" radio states the on-axis e.i.r.p. density shall not exceed 4 dBW in any 100 kHz band within the nominated bandwidth.

4.2.5.3 Conformance tests

Conformance tests shall be carried out in accordance with clause 6.6.

4.2.6 Antenna pointing and polarization alignment for ESVs

4.2.6.1 Justification

Protection of transmissions to adjacent satellites and cross-polarized transponders on the same satellite.

4.2.6.2 Specification

a) Mechanical stability:

Under the condition of 100 km/h maximum wind speed, with gusts of 130 km/h lasting 3 seconds, the installation shall not show any sign of permanent distortion that could affect the radiation subsystem of the ESV after the application of the wind load.

b) Pointing error detection:

The ESV shall be able to detect the pointing error. The ESV, when in the "Carrier-on" radio state, shall enter the "Carrier-off" radio state when the instantaneous pointing error exceeds the pointing error threshold, $\delta\phi$, relative to the direction of the wanted satellite at its actual position, within T seconds. The values of $\delta\phi$ and T shall be declared by the applicant and the value of T shall not exceed 5 s. The ESV shall not re-enter the "Carrier-on" radio state until the instantaneous pointing error is within $\delta\phi$ for a period of $2 \times T$ seconds.

The applicant may declare ranges of values for $\delta\phi$ as functions of on-axis e.i.r.p. spectral density such that the e.i.r.p. density limits in clause 4.2.3.2 are not exceeded.

c) Polarization angle alignment capability:

The polarization angle shall be adjustable within a range of at least 180°.

The misalignment error, α , of the transmit antenna polarization is the sum of the misalignment errors due to the tracking process plus, for ESVs that set the transmit polarization by tracking the receive polarization, the misalignment error of the transmit polarization plane relative to the receive polarization plane. The misalignment error, α , shall not exceed the maximum polarization misalignment, α_{\max} , such that:

$$\alpha_{\max} = \text{ArcTan} \left(\sqrt{\frac{\frac{10^{\frac{XPD_{\text{antenna}}[\text{dB}]}{10}} - 10^{\frac{XPD_{\text{ESV}}[\text{dB}]}{10}}}{10^{\frac{XPD_{\text{ESV}}[\text{dB}]}{10}} + XPD_{\text{antenna}}[\text{dB}]} - 1}}{10}}}{1}} \right)$$

where:

- XPD_{ESV} is the maximum equivalent cross polar discrimination (XPD) of the ESV as declared by the applicant;
- XPD_{antenna} is the antenna XPD at the centre frequency of the transmit band as declared by the applicant.

NOTE 1: Satellite operators may require specific values for XPD_{ESV} and they may also require the ESV to stop its transmissions (e.g. to enter the "Carrier-off" radio state) if the value XPD_{ESV} is exceeded.

NOTE 2: The lower bound XPD_{er} of the global XPD of the ESV antenna with a receiving antenna is given by the following formula:

$$XPD_{\text{er}} \geq \left(\frac{1 + \sqrt{XPD_{\text{ESV}}} \cdot \sqrt{XPD_r}}{\sqrt{XPD_{\text{ESV}} + XPD_r}} \right)^2$$

where:

- XPD_r is the XPD of the receiving satellite antenna.

4.2.6.3 Conformance tests

Conformance tests shall be carried out in accordance with clauses 6.7 to 6.9.

4.2.7 Cessation of emissions of the ESV

4.2.7.1 Justification

For cessation of emissions of the ESV to fulfil the requirements of ITU-R Resolution 902 (WRC-03) annex 1, item 6 [i.2] in locations where the ESV is not allowed to transmit.

4.2.7.2 Specification

4.2.7.2.1 Specification 1: Mode of cessation of emissions

At least one of the following two modes of cessation of emissions shall be implemented:

- a) the NCF determines that the ESV shall cease emissions; and/or
- b) the ESV autonomously determines that it shall cease emissions.

In addition, there shall be a "single-action" means (e.g. operating a switch) on the front panel of the ESV below deck unit by which a local operator may cease emissions.

Cessation of emissions shall be implemented in such a way that the corresponding mechanisms cannot be bypassed on board the vessel, except under the provisions of article 4.9 of the Radio Regulations of the ITU-R Radio Regulations [8].

NOTE: The capability to bypass these functions for emergency purposes is outside the scope of the present document.

The applicant shall declare the ESV interfaces involved in the cessation of emissions:

- the list of relevant parameters which are collected by the ESV or the NCF for determination as to whether the ESV should cease emissions;
- the list of these relevant parameters which are used by the ESV;
- the list of these relevant parameters which are transmitted by the ESV to the NCF;
- the list of the relevant parameters which are received by the ESV from the NCF;
- for the collected relevant parameters, the ESV interface (s), including the protocols, the timing, the ranges of the values, the speed of the variations and the required accuracies;
- for the relevant parameters transmitted to the NCF, the ESV interface with the NCF, including the protocols and the timing;
- for the transmission parameter received from the NCF, the ESV interface with the NCF, including the protocols and the timing;
- these declared ESV interfaces shall be in accordance with the user documentation.

4.2.7.2.2 Specification 2: Conditions under which the ESV shall cease emissions

For ESV networks where the NCF determines completely or partially where and under which conditions the emissions of the ESV shall be ceased, the collection of the relevant parameters by the ESV and the exchange of information between the ESV and the NCF shall be sufficient for the NCF to determine when to cease emissions with the accuracy declared by the applicant and to inform in time the ESV to cease emissions.

For ESVs which determine completely where and under which conditions the emissions shall be ceased, the collection of the relevant parameters by the ESV shall be sufficient for the ESV to determine when to cease emissions with the accuracy declared by the applicant.

The determination of these conditions shall take into account the inaccuracy of the ESV location and of the boundaries of the authorized operating areas in the data base used either by the ESV or the NCF, as declared by applicant.

The conditions for cessation of emissions shall take into account at least the following parameters:

- the location of the ESV and the boundaries of the authorized operating area;
- the operating parameters specified in annex 2 of ITU-R Resolution 902 (WRC-03) [i.2];
- the carrier frequency and the authorized frequency bands.

4.2.7.2.3 Specification 3: Cessation of emissions

When in the "Transmission enabled" state a condition requiring cessation of emissions occurs, the ESV shall cease transmissions and enter the "Transmission disabled" state.

When in the "Transmission disabled" state, the ESV shall not leave that state for the "Transmission enable" state as long as a condition requiring cessation of emissions exists or the last CC command received from the NCF is a transmission disable command.

When in the "Initial phase-1" and "Initial phase-2" radio state a condition requiring cessation of emissions occurs, the ESV shall cease transmissions and enter the "Initial phase-0" radio state.

When in the "Initial phase-0" radio state, the ESV shall not leave that state for the "Initial phase-1" or the "Transmission enabled" states as long as a condition requiring cessation of emissions exists.

The time for transition in any state from the occurrence of a condition requiring cessation of emissions to the "Emissions disabled" radio state shall not exceed 5 seconds.

4.2.7.2.4 Specification 4: Fault conditions

Any collection of the relevant parameters by the ESV or transmission of these parameters to the NCF, which have not been completed correctly within the required delay(s) as declared by the applicant, shall be considered as a fault condition.

Any transmission parameter not received or not correctly received from the NCF within the required delay declared by the applicant shall be considered as a fault condition.

These fault conditions shall be processed as conditions requiring cessation of emissions.

4.2.7.3 Conformance tests

Conformance tests shall be carried out in accordance with clause 6.10.

4.2.8 Identification of ESV

4.2.8.1 Justification

To fulfil the requirements of ITU-R Resolution 902 (WRC-03) annex 1, item 6 [i.2] for use by duly authorized entities.

4.2.8.2 Specification

The ESV shall be designed such that it is possible for the network operator to identify which ESVs are transmitting with at least 1 km accuracy in a given geographic area. The applicant shall declare the means by which identification of ESVs is accomplished. In the case where an external system is required, the applicant should declare which additional means are necessary for identification of the ESV.

4.2.8.3 Conformance tests

Conformance tests shall be carried out in accordance with clause 6.11.

4.2.9 Control and Monitoring Functions (CMFs)

4.2.9.1 CMF state diagram

The following minimum set of CMFs shall be implemented in ESVs in order to minimize the probability that they originate unwanted transmissions that may give rise to harmful interference to other systems.

In the "Non-valid" state and in the "Transmission disabled" state the ESV shall not transmit. In the "Transmission-enabled" state the ESV is allowed to transmit. In the "Initial phase" state the ESV is only allowed to transmit initial bursts.

NOTE 1: The restrictions in the "Initial phase" state are for the protection of other systems when the ESV is entering the system after a power-on or a reset. These initial burst restrictions do not apply to the ESV transmissions in the "Transmission-enabled" state and once a transmission enable command has been received by the ESV the ESV may transmit or not transmit as required.

Under any fault condition the ESV shall enter the "Non-valid" state where the e.i.r.p. limits for the "Emissions disabled" radio state apply.

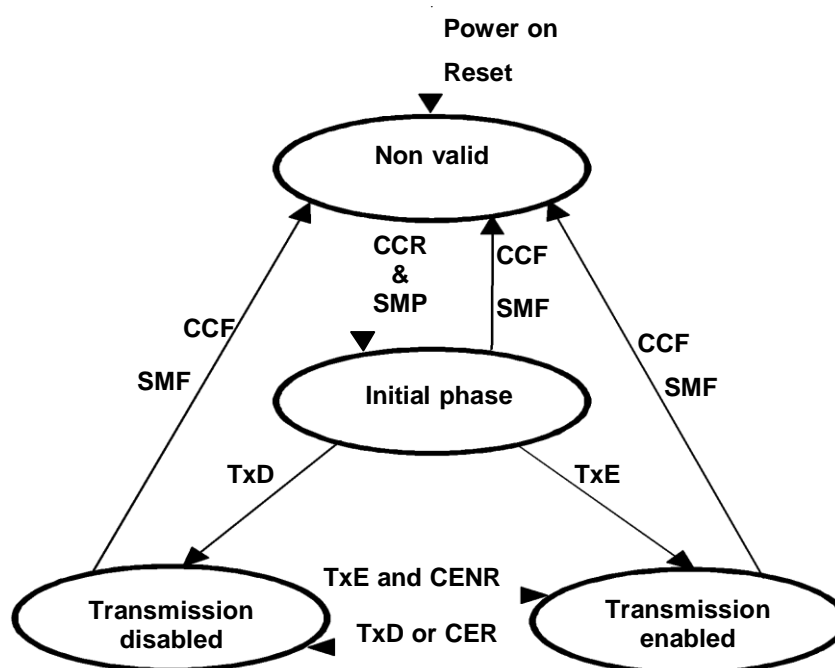

CER: Cessation of Emissions Required;
 CENR: Cessation of Emissions Not Required;
 SMP: System Monitoring Pass;
 SMF: System Monitoring Fail;
 TxE: Transmission Enable command;
 TxD: Transmission Disable command;
 CCR: Control Channel correctly Received;
 CCF: Control Channel reception Failure.

Figure 2: State transition diagram of the control and monitoring function of an ESV

NOTE 2: From "Transmission disabled" state a TxE command may also result in a transition towards the "Initial phase" state.

When the ESV transmits several carriers having different frequencies, an ESV state machine as described above may be associated with each carrier or each set of carriers. The events then apply to the subsystem associated with the specific carrier or the specific set of carriers, rather than the whole ESV.

4.2.9.2 Processor monitoring

4.2.9.2.1 Justification

To ensure that the ESV can suppress its transmissions in the event of a processor sub-system failure.

4.2.9.2.2 Specification

The ESV shall incorporate a processor monitoring function for each of its processors involved in maintaining the performance requirements of the present document and in Control and Monitoring Functions (CMF).

The processor monitoring function shall detect failures of these processors' hardware and software.

In the "Transmission enabled" state, the ESV shall enter the "Non valid" state or the "Carrier-off" radio state no later than 5 seconds after any fault condition occurs, and in any case it shall enter the "Non valid" state within 30 seconds until the processor monitoring function has determined that all fault conditions have been cleared. In any other state after any fault condition occurs, the ESV shall enter the "Non valid" state within 30 seconds until the processor monitoring function has determined that all fault conditions have been cleared.

4.2.9.2.3 Conformance tests

Conformance tests shall be carried out in accordance with clause 6.12.2.

4.2.9.3 Transmit subsystem monitoring

4.2.9.3.1 Justification

To ensure the inhibition of transmissions that are potentially harmful to other systems in the event of incorrect operation of the transmit frequency generation sub-system.

4.2.9.3.2 Specification

The ESV shall monitor the operation of its transmit frequency generation sub-system and shall be able to detect:

- a) loss of frequency lock (if applicable);
- b) failure of the Local Oscillator (LO).

No later than 5 seconds after any of these fault conditions of the transmit frequency generation sub-system occurs, the ESV shall enter the "Non-valid" state until the transmit sub-system monitoring function has determined that all fault conditions have been cleared.

4.2.9.3.3 Conformance tests

Conformance tests shall be carried out in accordance with clause 6.12.3.

4.2.9.4 Power-on/Reset

4.2.9.4.1 Justification

To demonstrate that the ESV achieves a controlled non-transmitting state following the powering of the unit, or the occurrence of a reset made by a local operator when this function is implemented.

4.2.9.4.2 Specification

Following a manual reset, when this function is implemented, the ESV shall enter the "Non-valid" state.

During and following "power-on" the ESV shall remain in the "Non-valid" state.

4.2.9.4.3 Conformance tests

Conformance tests shall be carried out in accordance with clause 6.12.4.

4.2.9.5 Control Channel (CC) and Response Channel (RC)

4.2.9.5.1 Justification

Control Channels (CC) are used by ESVs to receive control information from the NCF and Response Channels (RCs) to respond to the NCF. For ESV designed to operate within networks where the NCF determines that the ESV shall cease emissions, then the CCs and RCs are also used for the dialogue with the NCF.

To ensure that the ESV cannot transmit unless it receives the CC messages from the NCF.

4.2.9.5.2 Specification

4.2.9.5.2.1 Specification 1: types of CCs and RCs

- a) The ESV shall have at least one CC and one RC with the NCF. Each CC and each RC may be internal or external.

The types (internal or external) of each CC and each RC shall be declared by the applicant.

NOTE 1: The availability of the network carrying the external CC(s) and RC(s) and the numbers of external CC(s) and RC(s) are not within the scope of the present document.

NOTE 2: Some satellite operators may require that internal CC(s) and or RC(s) are available.

- b) The connection between the NCF and the ESV via the CCs and RCs shall be either permanent or shall be set up on a call by call basis through a switched network. In case of connection through a switched network the ESV shall be able to receive calls from the NCF and to initiate calls towards the NCF in order to set up the CCs and RCs.
- c) The ESV with an external CC shall not transmit without receiving an appropriate signal from the NCF through the satellite to which the ESV transmits, indicating to the ESV that the NCF is alive and insuring that the ESV is pointing to the target satellite.

4.2.9.5.2.2 Specification 2: CC Reception

- a) The ESV shall immediately enter the "Non-valid" state when it is not able to correctly receive messages through the CC, from the NCF, for a period not exceeding 30 seconds. This event is called a "CC disruption".

In the case of external CCs and RCs without permanent connection of the NCF with the ESV, the ability to receive CC messages from the NCF is the ability to receive calls and messages from the network through a permanent connection to the switched network to which is connected the NCF.

The inability to receive CC messages from the NCF may be due to the following various causes but not limited to them: no received signal from the NCF or from the network, a too low level received signal, no network accessible, the inability to lock onto the received carrier frequency, to demodulate, to decode, to receive calls and/or messages, a hardware failure or power off.

- b) The ESV shall remain in the "Non-valid" state as long as the ESV is unable to receive CC messages from the NCF.
- c) From the "Non-valid" state the ESV may enter the "Initial phase" state if the following conditions are met:
 - the ESV is able to receive CC messages from the NCF; and
 - no fault conditions are present.

4.2.9.5.3 Conformance tests

Conformance tests shall be carried out in accordance with clause 6.12.5.

4.2.9.6 Network control commands

4.2.9.6.1 Justification

These requirements ensure that the ESV is capable of:

- a) retaining a unique identification in the network;
- b) receiving commands from the NCF through its CC(s) and executing those commands.

4.2.9.6.2 Specification

The ESV shall hold, in non-volatile memory, its unique identification code in the network.

The ESV shall be capable of receiving through its CCs dedicated messages (addressed to the ESV) from the NCF, and which contain:

- transmission enable commands (TxE);
- transmission disable commands (TxD).

When in the "Initial phase" or "Transmission enabled" states, once a transmission disable command is received, within 1 second the ESV shall enter into, and shall remain in the "Transmission disabled" state until the transmission disable command is superseded by a subsequent transmission enable command.

When in the "Initial phase" or "Transmission disabled" states, once a transmission enable command is received, the ESV may enter into the "Transmission enabled" state.

When entering the "Initial phase" from the "Non-valid" state, the last TxE or TxD command received from the NCF may be used by the ESV to enter the "Transmission enabled" state or the "Transmission disabled" state, respectively, if since the time of reception of that command no "CC disruption" occurred.

NOTE: The physical unit in charge of the reception of the CCs, of the transmissions of the RCs and of the CC commands reception may be a separate and independent unit from the other units of the ESV and it may be common to several ESVs.

4.2.9.6.3 Conformance test

Conformance tests shall be carried out in accordance with clause 6.12.6.

4.2.9.7 Initial burst transmission

4.2.9.7.1 Justification

Restrictions on the initial burst transmissions are necessary to limit disturbance to other services.

4.2.9.7.2 Specification

For systems where no transmission enable command is foreseen without request from the ESV, in the "Initial phase" state the ESV may transmit initial bursts:

- a) The ESV shall not start the transmission of initial bursts before having obtained a confirmation that no cessation of emission applies where the ESV is located. This confirmation shall be obtained either by local means of determination of the cessation of emissions (see clause 4.2.7) or from the NCF via an external control channel.
- b) The duty cycle of the burst retransmission shall not exceed 0,2 %, where the duty cycle is defined as the ratio of burst duration to the duration between two successive bursts.
- c) Each burst shall not carry more than 256 data bytes excluding the burst preambles and the FEC coding bits.
- d) The initial burst shall be transmitted at an e.i.r.p. no greater than $EIRP_{nom}$.

- e) The duration between two successive bursts shall not be less than the required NCF response time as declared by the applicant. This response time is defined as the duration, measured at the ESV, between an initial burst transmission and the reception and processing of a transmission enable or disable command from the NCF which is never exceeded during 99 % of the cases under normal conditions in the system for which the ESV is designed, as declared by the applicant.

NOTE: The present document does not address the possibility for ESVs of transmitting initial bursts in locations where transmissions are not permitted. This possibility is under study within CEPT/ECC WGSE.

4.2.9.7.3 Conformance tests

Conformance tests shall be carried out in accordance with clause 6.12.7.

4.2.10 Receive antenna off-axis gain pattern

4.2.10.1 Justification

To protect the wanted signals from interference from terrestrial services and from other satellite services.

4.2.10.2 Specification

The maximum antenna gain of each of the co-polarized components in any direction ϕ degrees from the antenna main beam axis shall not exceed the following limits:

$$G = 32 - 25 \log \phi \quad \text{dBi} \quad \text{for } \phi_{min} \leq \phi < 48^\circ$$

$$G = -10 \quad \text{dBi} \quad \text{for } 48^\circ \leq \phi \leq 85^\circ$$

$$G = 0 \quad \text{dBi} \quad \text{for } 85^\circ \leq \phi \leq 180^\circ$$

where:

$\phi_{min} = 1^\circ$ or $100 \lambda/D$ degrees, whichever is the greater, for $D/\lambda \geq 50$.

$\phi_{min} = 2^\circ$ or $114 (D/\lambda)^{-1.09}$ degrees, whichever is the greater, for $D/\lambda < 50$.

D is the nominal diameter of the antenna.

In addition the maximum antenna gain of each of the cross-polarized components in any direction ϕ degrees from the antenna main beam axis shall not exceed the following limits:

$$G_x(\phi) = 23 - 20 \log \phi \quad \text{dBi} \quad \text{for } \phi_r \leq \phi \leq 7^\circ$$

where ϕ_r is equal to 1° or $100 \lambda/D$, whichever is greater.

4.2.10.3 Conformance tests

Conformance tests shall be carried out in accordance with clause 6.13.

4.2.11 Blocking performance

4.2.11.1 Justification

To prevent high power signals outside the receive frequency band from blocking the reception of signals inside the receive frequency band.

4.2.11.2 Specification

Receiver blocking is characterized here through gain compression for a signal inside the receive frequency band that is caused by another signal outside the receive frequency band at high power. The level of the other signal is compared to the level of a signal inside the receive frequency band that would cause the same gain compression.

Receiver blocking rejection at a particular frequency is defined as the level of a second signal at this frequency that causes a certain gain compression to a first signal inside the receive frequency band, minus the level of a second signal at a frequency inside the receive frequency band that causes the same gain compression.

The first signal shall be at the centre frequency of the receive frequency band and have a level in the operational range. The second signal shall cause a gain compression for the first signal of 1 dB.

The rejection shall comply with table 5.

Table 5: Receiver blocking rejection

Frequency	Minimum rejection
below 9 GHz	20 dB
9 to 10 GHz	10 dB
14 to 16 GHz	10 dB
Above 16 GHz	20 dB

NOTE: In the frequency ranges 10 to 10,7 GHz and 12,75 to 14 GHz, the rejection needs further studies.

4.2.11.3 Conformance tests

Conformance tests shall be carried out in accordance with clause 6.14.

4.2.12 Adjacent Signal Selectivity

4.2.12.1 Justification

To enable reception of a wanted signal in presence of other signals on adjacent frequencies which are transmitted with high EIRP density from target satellite orbital position.

NOTE: The power level of signals transmitted from the same orbital position are under control of the satellite operator. Signals transmitted from an adjacent orbital position that is not near-by are suppressed by the antenna gain pattern.

4.2.12.2 Specification

Adjacent Signal Selectivity is a measure of a receiver's ability to receive a signal at its assigned channel frequency in the presence of an adjacent signal at a given frequency offset from the centre frequency of the assigned channel. The adjacent signal shall occupy the same bandwidth as the wanted signal. Frequency offset and relative power level of the adjacent signal compared to the wanted signal shall take the value given in table 6. BW is the wanted signal occupied bandwidth.

Table 6: Adjacent signal frequency and Power level

Signal	Centre frequency offset from wanted signal	Power level relative to wanted signal
Adjacent Carrier	BW	7 dBsd

The decrease in the required signal to noise ratio in the presence of an adjacent signal shall be no more than 0,5 dB.

4.2.12.3 Conformance tests

Conformance tests shall be carried out in accordance with clause 6.15.

5 Testing for compliance with technical requirements

5.1 Environmental conditions for testing

Tests defined in the present document shall be carried out at representative points within the boundary limits of the declared operational environmental profile.

5.2 Essential radio test suites

The essential radio test suites for a complete ESV are given in clause 6.

6 Test methods for the complete ESV

6.1 General

The values of measurement uncertainty associated with each measurement parameter apply to all of the test cases described in the present document. The measurement uncertainties shall not exceed the values shown in tables 7 and 8.

Table 7: Measurement uncertainty

Measurement parameter	Uncertainty
Radio frequency	±10 kHz
RF power	±0,75 dB
Conducted spurious	±4 dB
Radiated spurious	±6 dB
Antenna on-axis gain	±1,0 dB
Polarization discrimination	±2 dB
Angles	0,1°

Table 8: Measurement uncertainties for antenna gain pattern

Gain relative to the antenna on-axis gain	Uncertainty
> -3 dB	±0,3 dB
-3 dB to -20 dB	±1,0 dB
-20 dB to -30 dB	±2,0 dB
-30 dB to -40 dB	±3,0 dB

NOTE: ETSI TR 102 215 [i.3] gives guidance on interpretation of measurement uncertainty and interpretation of results.

To enable the performance tests to be carried out the use of an NCF or a Special Test Equipment (STE), made available by the applicant or system provider, may be necessary. Since this STE will be specific for the particular system, it is not possible to provide detailed specifications in the present document. However, the following baseline is provided:

- if the ESV requires to receive a modulated carrier from the satellite in order to transmit, then special test arrangements are required to simulate the satellite signal, thus enabling the ESV to transmit allowing measurement of transmission parameters;
- any characteristic of these special test arrangements which may have direct or indirect effects on the parameters to be measured shall be clearly stated by the applicant.

The test procedures specified in clause 6 may be replaced by other equivalent procedures provided that the results are proven to be as accurate as those obtained according to the specified method.

All tests with carrier-on shall be undertaken with the transmitter operating at $EIRP_{nom}$ or $EIRP_{max}$, as per the specific requirement, and with the maximum transmit burst rate, where applicable, which shall be declared by the applicant.

If the Equipment Under Test (EUT) is an ESV that has had hardware and/or software modification(s) performed by the applicant for these tests then full documentation of such modification(s) shall be provided to prove that the modification(s) will simulate the required test condition. Such modification(s) shall be proved to allow the ESV to operate without its main characteristics being changed.

All technical characteristics and operational conditions declared by the applicant shall be entered in the test report.

For testing under this clause 6 the cable lengths used should be the maximum lengths declared by the applicant. For maximum cable lengths longer than 10 m, the tests may be performed with cables no shorter than 10 m.

6.2 Off-axis spurious radiation

6.2.0 General

The tests for the ESV specification 3) shall be limited to the "Carrier-on" radio state. The tests shall be undertaken with the transmitter operating at $EIRP_{max}$.

6.2.1 Test method

6.2.1.a General

An EUT with antenna is an ESV with its antenna. It comprises both the below-deck and above-deck units interconnected by the appropriate cable(s). An EUT without antenna is an ESV with the removable antenna removed. It comprises both the below-deck and above-deck units, up to the antenna flange, interconnected by the appropriate cable(s). The connecting cable(s) between the below-deck and the above-deck units shall be the same types as recommended by the applicant in the installation manual. The type of each cable used shall be entered in the test report.

The below-deck unit shall be terminated with matched impedances at the telecommunication ports if there is no associated equipment connected to such ports if recommended by the applicant in the user documentation.

For frequencies up to 80 MHz the measuring antenna shall be a balanced dipole with a length equal to the 80 MHz resonant length and shall be matched to the feeder by a suitable transforming device. Measurements with broad band antennas are also possible provided that the test site has been calibrated according to the requirements of CISPR 16-1-5 [6].

For frequencies between 80 MHz and 1 000 MHz the measuring antenna shall be a balanced dipole which shall be resonant in length. Measurements with broad band antennas are also possible provided that the test site has been calibrated according to the requirements of CISPR 16-1-5 [6].

For frequencies above 1 000 MHz the antenna shall be a horn radiator of known gain/frequency characteristics. When used for reception the antenna and any associated amplification system, the combined amplitude/frequency response calibration curves shall be verified across the measurement frequency range considered for the antenna, to account for the interaction between the components. The antenna is mounted on a support capable of allowing the antenna to be used in either horizontal or vertical polarization and at the specified height.

Unused input and output ports of the EUT shall be connected to cables of the appropriate length (see clause 6.1) and terminated to simulate the impedance of the relevant ports of the radio equipment. These cables shall be bundled at the approximate centre of the cable with the bundles of 30 cm to 40 cm in length running in the horizontal plane from the port to which it is connected. If it is impractical to do so because of cable bulk or stiffness, the disposition of the excess cable shall be precisely noted in the test report.

The radiations shall be measured in the frequency range of 30 MHz to 2 GHz in accordance with CISPR 16-1 [5] using the measuring receiver or a comparable spectrum analyser. During the measurements up to 1 GHz the quasi-peak detector shall be used, for measurements in the frequency range 1 GHz to 2 GHz a peak detector shall be used.

In addition, for the frequency band 156 MHz to 165 MHz, the measurement shall be repeated with a receiver bandwidth of 9 kHz to 10 kHz. The equipment shall meet both, the quasi peak and the peak emission limits set out in table 2.

6.2.1.0 Multi-carrier operation

For ESVs designed to transmit simultaneously several carriers the verification below 2 000 MHz shall be performed with the minimum number of carriers and the verification above 2 000 MHz shall be repeated for each combination of carriers declared by the applicant.

For each combination of carriers the applicant shall declare the carriers' centre frequencies and characteristics, the maximum value of the total on-axis e.i.r.p. of the carriers and the relative levels of the carriers (in dBs) at the input or output of the HPA or antenna.

In the case of combinations of carriers with identical characteristics and when the Global Input Back-Off at the input of the HPA does not exceed the maximum Global Input Back-Off at the input of the HPA of two carriers, the verification may be limited to the case with two carriers and with the maximum frequency separation between them.

In any other case, the number of configurations to be verified above may be limited to the cases which can be proven by the applicant, by documentary evidence or demonstration, to generate the maximum e.i.r.p. density level of the out-of-band emissions due to inter-modulation products.

6.2.1.1 Up to 2 000 MHz

6.2.1.1.1 Test site

The test method shall be in accordance with CENELEC EN 60945 [7] and the test site shall also be in accordance with CENELEC EN 60945 [7] as well as CISPR 16-1-5 [6], with the following modifications.

The test shall be performed either in an open area test site, a semi-anechoic chamber or an anechoic chamber. Ambient noise levels shall be at least 6 dB below the applicable unwanted emissions limit.

The open area test site shall be flat, free of overhead wires and nearby reflecting structures, sufficiently large to permit aerial placement at the specified measuring distance and provide adequate separation between aerial, test unit and reflecting structures, according to the specification of CISPR 16-1-5 [6].

For both the open area test site and the semi-anechoic chamber a metal ground plane shall be inserted on the natural ground plane and it shall extend at least 1 m beyond the perimeter of the EUT at one end and at least 1 m beyond the measurement antenna at the other end. The EUT shall be placed on a non-conductive support.

The distance between the EUT and measuring antenna should be 3 m for measurements below 2 000 GHz. For measurements at a different distance an inverse proportionality factor of 20 dB per decade shall be used to normalize the measured data to the specified distance for determining compliance. Care should be taken in measurement of large test units at 3 m at frequencies near 30 MHz due to near field effects.

The measuring bandwidth shall be in accordance with table 2.

The setting of controls which may affect the level of radiated interference shall be varied in order to ascertain the maximum emission level. Measuring receivers.

Measuring receivers shall conform to the following characteristics:

- the response to a constant amplitude sine wave signal shall remain within ± 1 dB across the frequency range of interest;
- quasi-peak detection shall be used in a -6 dB bandwidth of 120 kHz;
- the receiver shall be operated below the 1 dB compression point.

6.2.1.1.2 Procedure

- a) The EUT shall be an EUT with antenna or, preferably, without antenna but with the antenna flange terminated by a dummy load.
- b) The EUT shall be in the "Carrier-on" radio state.
- c) The EUT shall be rotated through 360 ° and, except in an anechoic chamber, the measuring antenna height simultaneously varied from 1 m to 4 m above the ground plane.
- d) All identified spurious radiations shall be measured and noted in frequency and level.

6.2.1.2 Above 2 000 MHz

6.2.1.2.0 General

The spectrum analyser resolution bandwidth shall be set to the specified measuring bandwidth or as close as possible. If the resolution bandwidth is different from the specified measuring bandwidth, bandwidth correction shall be performed for the noise-like wideband spurious.

For an EUT with antenna the tests shall be performed in two stages for both the "Carrier-on" and "Carrier-off" radio states:

- Procedure a) Identification of the significant frequencies of spurious radiation;

- Procedure b) Measurement of radiated power levels of identified spurious radiation.

NOTE: Testing for an EUT with antenna attached is not recommended due to difficulties in achieving the required measurement accuracy.

For an EUT without antenna the tests shall be performed in three stages for both the "Carrier-on" and "Carrier-off" radio states:

- Procedure a) Identification of the significant frequencies of spurious radiation;
- Procedure b) Measurement of radiated power levels of identified spurious radiation;
- Procedure c) Measurement of conducted spurious radiation at the antenna flange.

6.2.1.2.1 Identification of the significant frequencies of spurious radiation

6.2.1.2.1.1 Test site

The identification of frequencies emitting from the EUT shall be performed either in an anechoic chamber, an open area test site or a semi-anechoic chamber with the test antenna close to the EUT and at the same height as the volume centre of the EUT.

6.2.1.2.1.2 Procedure

- a) The EUT shall be in the "Carrier-off" radio state.
- b) For an EUT with antenna the main beam of the antenna shall have an angle of elevation equal to 7 ° or to the minimum angle of elevation declared by the applicant, whichever is greater, and, for an EUT without antenna the antenna flange shall be terminated by a dummy load.
- c) The receivers shall scan the frequency band whilst the EUT revolves.
- d) The EUT shall be rotated through 360 ° and the frequency of any spurious signals noted for further investigation.
- e) For an EUT with antenna the test shall be repeated with the test antenna being in the opposite polarization.
- f) The test shall be repeated in the "Carrier-on" radio state whilst transmitting one modulated carrier at maximum power.

6.2.1.2.2 Measurement of radiated power levels of identified spurious radiation

6.2.1.2.2.1 Test site

The measurement of each spurious radiation noted during procedure a) of the test shall be performed on a test site that is free from reflecting objects, i.e. either an open-area test site, a semi-anechoic chamber or an anechoic chamber.

6.2.1.2.2.2

Procedure

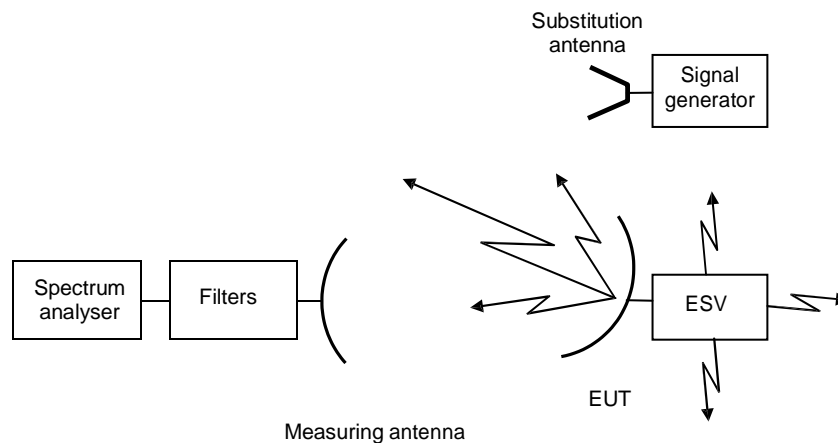

Figure 3: Test arrangement - spurious radiation measurement above 2 000 MHz for an EUT with antenna

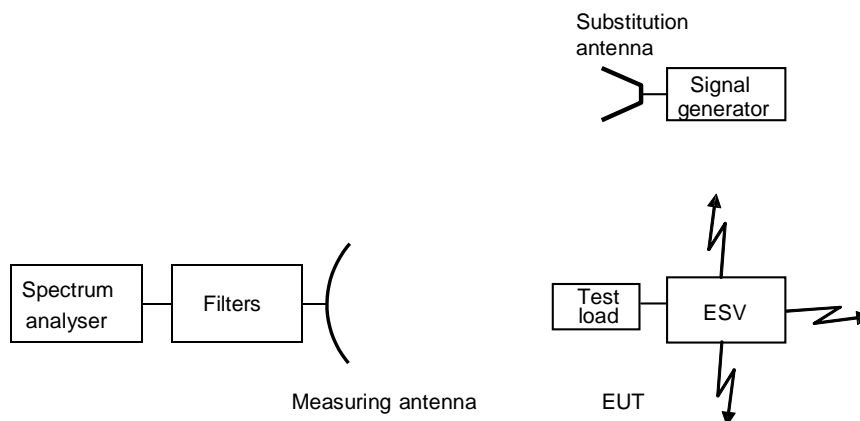

Figure 4: Recommended test arrangement - spurious radiation measurements above 2 000 MHz for an EUT without antenna

- The test arrangement shall be as shown in figure 3 or preferably figure 4. A tuneable notch filter should be used to remove the wanted (non-spurious) signal. However, precautions should be taken to prevent spectrum analyser damage due to accidental filter mistuning during test or other potentially harmful scenarios.
- The EUT shall be installed such that the units are separated by about 1 m to 2 m with the below-deck unit at a height between 0,5 m and 1,0 m on a turntable. The interconnection cable shall be maintained by non-metallic means at a height between 0,5 m and 1,0 m. For the test arrangement shown in figure 3 the main beam of the antenna shall have an angle of elevation equal to 7° or to the minimum angle of elevation declared by the applicant, whichever is greater, and be oriented away from the geostationary orbit, or be inhibited by placing RF absorbing panels in that direction. For antennas designed for minimum off-axis gain in the direction of the geostationary orbit plane, the plane containing the larger cut of the main lobe shall be set vertical.
- The measuring antenna shall be positioned at a distance from the EUT (e.g. 3 m, 5 m, 10 m) relevant to the applied test site. The measuring antenna shall be adjusted in height and the EUT rotated, whilst the EUT is in the appropriate carrier condition, for a maximum response on the associated spectrum analyser at each spurious frequency previously identified, this response level shall be noted. The adjustment in height of the measuring antenna does not apply when an anechoic chamber is being used. The measuring antenna shall never enter the 7° off-axis cone around the main beam direction.
- The investigation shall be repeated with the measuring antenna in the opposite polarization and the response level similarly noted.

- e) The EUT shall be replaced by the substitution antenna to which is connected a signal generator. The main beam axes of the measuring and substitution antennas shall be aligned. The distance between these antennas shall be the distance determined under test c).
- f) The substitution and measuring antennas shall be aligned in the polarization which produced the larger response between the EUT and the test antenna in steps c) and d).
- g) The output of the generator shall be adjusted so that the received level is identical to that of the previously noted largest spurious radiation.
- h) The output level of the signal generator shall be noted. The e.i.r.p. of the spurious radiation is the sum, in dB, of the signal generator output plus the substitution antenna isotropic gain minus the interconnection cable loss.

6.2.1.2.3 Measurement of conducted spurious radiation at the antenna flange

6.2.1.2.3.1 Test site

There are no requirements for the test site to be used for this test.

6.2.1.2.3.2 Procedure

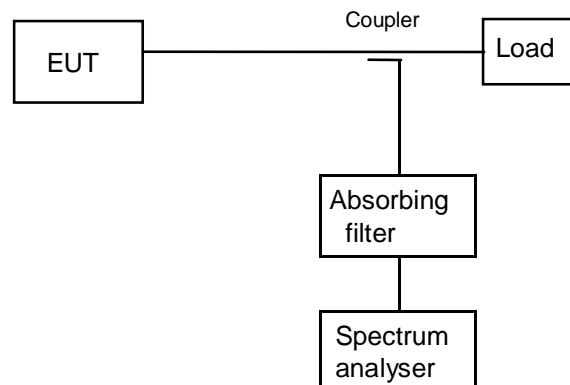

Figure 5: Test arrangement - conducted spurious radiation above the cut-off frequency

- a) The test arrangement shall be as shown in figure 5. In order to protect the spectrum analyser while ensuring the necessary measurement accuracy, particularly close to the carrier, if an absorbing filter is used it shall be tuned to the transmit carrier frequency.
- b) The frequency range from the cut-off frequency of the waveguide of the EUT to 40 GHz shall be investigated for spurious radiation whilst in the "Carrier-on" radio state with the carrier being at maximum power and normally modulated.
- c) To obtain the off-axis spurious e.i.r.p. the maximum measured antenna transmit gain, measured at the frequency of the identified unwanted emission, for off-axis angles greater than 7°, shall be added to the measured power density and any correction or calibration factors summated with the result. If agreed by the applicant, it shall be acceptable that the worst case value assumed (i.e. 8 dBi for off-axis angles greater than 7°) is used in place of the maximum off-axis antenna gain at the frequency of the identified unwanted emission.
- d) The test shall be repeated, for transmit capable equipment, in the "Carrier-off" radio state.

6.3 On-axis spurious radiation

6.3.1 Test method

6.3.1.1 Test site

There are no requirements for the test site to be used for this test.

6.3.1.2 Method of measurement

6.3.1.2.1 General

The tests shall be undertaken with the transmitter operating at $EIRP_{max}$.

For ESV equipment for which measurements at the antenna flange are not possible or not agreed by the applicant, the measurements shall be performed with a test antenna.

For ESV equipment for which measurements at the antenna flange are possible and agreed by the applicant, the measurements shall be performed at the antenna flange. The EUT is the ESV with its antenna comprising both the below- and above-deck units interconnected by appropriate cables.

6.3.1.2.2 Method of measurement at the antenna flange

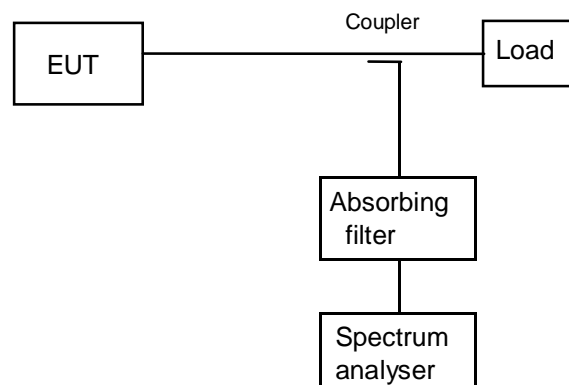

Figure 6: Test arrangement - on-axis spurious radiation measurements at the antenna flange

- a) The test arrangement shall be as shown in figure 6. In order to protect the spectrum analyser while ensuring the necessary measurement accuracy, particularly close to the carrier, if an absorbing filter is used it shall be tuned to the transmit carrier frequency.
- b) The EUT shall transmit one modulated carrier continuously, or at its maximum burst rate where applicable, centred on a frequency as close to the lower limit of the operating frequency band of the EUT as possible. The EUT shall be operated at the highest normal operating e.i.r.p. The frequency range 14,00 GHz to 14,50 GHz shall be investigated.
- c) Due to the proximity of the carrier the spectrum analyser resolution bandwidth shall be set to a measurement bandwidth of 3 kHz, or as close as possible. If the measurement bandwidth is different from the specified measurement bandwidth, bandwidth correction shall be performed for noise-like wideband spurious radiation.
- d) To obtain the on-axis spurious e.i.r.p., the antenna transmit gain shall be added to any figure obtained in the above measurement and any correction or calibration factor summated with the result. The antenna gain shall be as measured in clause 6.5.1.3 at the closest frequency to the spurious frequency.
- e) The tests in b) to e) shall be repeated with a transmit frequency in the centre of the operating frequency band. f) The tests in b) to e) shall be repeated with a transmit frequency as close to the upper limit of the operating frequency band of the EUT as possible.
- g) The test shall be repeated in the "Carrier-off" radio state.
- h) The test shall be repeated in the "Emissions disabled" radio state.

6.3.1.2.3 Method of measurement with a test antenna

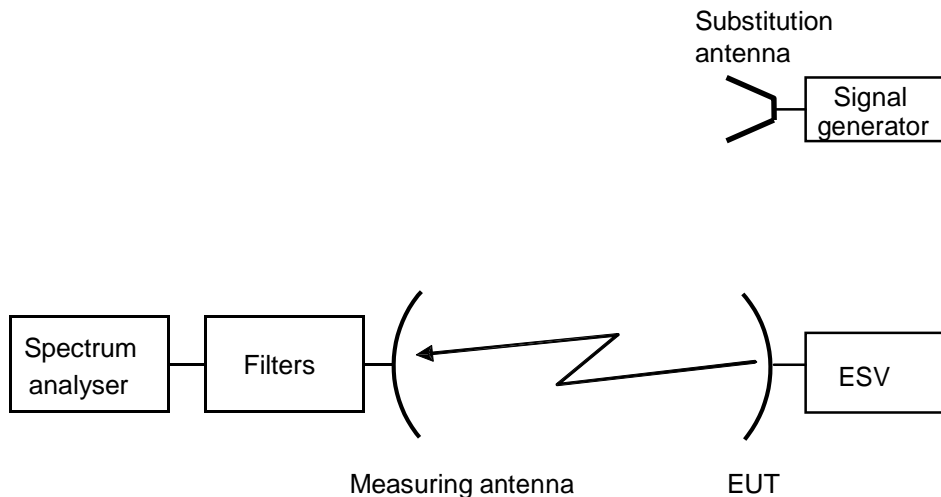

Figure 7: Test arrangement - on-axis spurious radiation measurements for an EUT with antenna

- a) The test arrangement shall be as shown in figure 7.
- b) The EUT shall be installed such that the units are separated by about 1 m to 2 m with the below-deck unit at a height between 0,5 m and 1,0 m on a turntable. The interconnection cable shall be maintained by non-metallic means at a height between 0,5 m and 1,0 m.
- c) The spectrum analyser resolution bandwidth shall be set to the specified measuring bandwidth or as close as possible. If the resolution bandwidth is different from the specified measuring bandwidth, bandwidth correction shall be performed for noise-like wideband spurious radiation.
- d) The EUT shall transmit the modulated carrier(s) continuously, or at its maximum burst rate where applicable, centred on a frequency as close to the lower limit of the operating frequency band of the EUT as possible. The EUT shall be operated at $EIRP_{max}$. The frequency range 14,00 GHz to 14,50 GHz shall be investigated and each spurious frequency shall be noted.
- e) Due to the proximity of the carrier the spectrum analyser resolution bandwidth shall be set to a measurement bandwidth of 3 kHz, or as close as possible. If the measurement bandwidth is different from the specified measurement bandwidth, bandwidth correction shall be performed for noise-like wideband spurious radiation.
- f) The measuring antenna shall be positioned at a distance from the EUT (e.g. 3 m, 5 m, 10 m) relevant to the applied test site and shall be aligned with the EUT antenna for the transmit frequency. The measuring antenna shall be adjusted in height, whilst the EUT is in the appropriate carrier condition, for a maximum response on the associated spectrum analyser at each spurious frequency previously identified, this response level shall be noted. The adjustment in height of the measuring antenna does not apply when an anechoic chamber is being used.
- g) The EUT shall be replaced by a representative substitution antenna to which is connected a signal generator. The main beam axes of the measuring and substitution antennas shall be aligned. The distance between these antennas shall be the distance determined under test f).
- h) The substitution and measuring antennas shall be aligned in the polarization which produced the largest response between the EUT and the test antenna.
- i) The output of the generator shall be adjusted so that the received level is identical to that of the previously noted largest spurious radiation.
- j) The output level of the signal generator shall be noted. The e.i.r.p. of the on-axis spurious radiation is the sum, in dB, of the signal generator output plus the substitution antenna isotropic gain minus the interconnection cable loss.
- k) The tests in d) to j) shall be repeated with a transmit frequency in the centre of the operating frequency band.

- l) The tests in d) to j) shall be repeated with a transmit frequency as close to the upper limit of the operating frequency band of the EUT as possible.
- m) The test shall be repeated in the "Carrier-off" radio state.
- n) The test shall be repeated in the "Emissions disabled" radio state.

6.4 Maximum ESV emissions towards the horizon

6.4.1 Test method

6.4.1.1 Maximum e.i.r.p. towards the horizon

- a) The co-polarization radiation pattern in the elevation plane shall be taken from measurements made in clause 6.5.1.4.5.
- b) The maximum e.i.r.p. towards the horizon, $EIRP_{horizon}$ (dBW), shall be calculated from:

$$EIRP_{horizon} = EIRP_{max} - G_{max_on_axis} + G_{max_horizon}$$

where:

- $EIRP_{max}$ is the maximum on-axis e.i.r.p. (dBW) as declared by the applicant;
 - $G_{max_on_axis}$ is the maximum on-axis antenna gain (dBi), as measured in clause 6.5.1.3;
 - $G_{max_horizon}$ is the maximum antenna gain (dBi) towards the horizon within the range of the declared operational elevation angles. The determination of $G_{max_horizon}$ shall take into account the maximum pointing threshold, $\delta\phi$ as declared by the applicant, for operating elevation angles on the main beam.
- c) It shall be verified that the $EIRP_{horizon}$ does not exceed 16,3 dBW (clause 4.2.3.2.2).

6.4.1.2 Maximum e.i.r.p. spectral density towards the horizon

- a) The co-polarization radiation pattern in the elevation plane shall be taken from measurements made in clause 6.5.1.4.5.
- b) The maximum e.i.r.p. spectral density towards the horizon, $EIRP_{sd_horizon}$ (dBW/1MHz), shall be calculated from:

$$EIRP_{sd_horizon} = PSD_{max} + G_{max_horizon}$$

where:

- PSD_{max} is the maximum power spectral density (dBW/1MHz) at the antenna flange measured using the procedure in clause 6.5.2 using a resolution bandwidth of 1 MHz instead of 40 kHz and performed at $EIRP_{max}$;
 - $G_{max_horizon}$ is as defined above in clause 6.4.1.1.
- c) It shall be verified that the $EIRP_{sd_horizon}$ does not exceed 12,5 dBW/1MHz (clause 4.2.3.2.1).

6.5 Off-axis e.i.r.p. emission density within the band

6.5.0 General

Off-axis e.i.r.p. emission density (co-polar and cross-polar) within the band 14,0 GHz to 14,5 GHz.

6.5.1 Test method

6.5.1.1 General

The measurement shall be made in the operational configuration(s) (occupied bandwidth, $EIRP_{nom}$) producing the highest emission density in the frequency band. The selected configuration(s) shall be recorded in the test report. All of the e.i.r.p. emission density measurement shall be performed at $EIRP_{nom}$.

If the test is to be carried out with an STE, then the STE shall provide all the signals needed by the ESVs under normal operation (e.g. a radio beacon if it is expected to be received by the satellite).

For ESVs with uplink power control capability, the compliance of the ESV with the specification of clause 4.2.4.2 during fading conditions shall be demonstrated by documentary evidence from the applicant.

The e.i.r.p. densities are determined from the measurements of the antenna copolar and crosspolar gain patterns, and of the power density at the antenna flange. These e.i.r.p. densities shall be compared to the specified masks.

To ascertain the off-axis e.i.r.p. it is necessary to know the transmit power density and antenna transmit radiation pattern. To ascertain the radiation pattern it is necessary to know the antenna transmit gain.

The following three measurement procedures shall, therefore, be performed:

- transmit output power density (dBW/40 kHz);
- antenna transmit gain (dBi);
- antenna transmit radiation patterns (dBi).

6.5.1.2 Transmit output power density

6.5.1.2.1 General

For the purpose of this test the EUT is defined as the below deck unit and that part of the above deck unit up to the antenna flange.

The EUT output power shall be set to the power corresponding to $EIRP_{nom}$.

6.5.1.2.2 Test site

There are no requirements for the test site to be used for this test.

6.5.1.2.3 Method of measurement

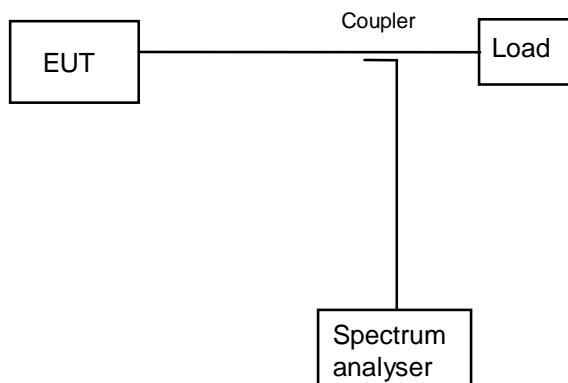

Figure 8: Test arrangement - transmit output power density measurement

- The test arrangement shall be as shown in figure 8.
- The EUT shall transmit the carrier(s) modulated with data or with a pseudo random signal. For burst mode transmission the EUT shall transmit at its maximum burst-rate. The power density supplied to the antenna flange shall be measured in dBW/40 kHz. The coupling factor of the test coupler at the test frequency and the attenuation of any necessary waveguide adapter shall be taken into account.

The spectrum analyser shall be operated under the following conditions:

- Frequency span:
As required for the complete nominated bandwidth.
- Resolution bandwidth:
The resolution bandwidth of the spectrum analyser shall be set as close as possible to the specified measuring bandwidth of 40 kHz. If the resolution bandwidth is different from the specified bandwidth then bandwidth correction shall be performed except for spectrum components the width of which are narrower than the measurement bandwidth.
- Display/video bandwidth:
Equal to the resolution bandwidth.
- Averaging:
Yes.
- Max hold:
No.

If required by the applicant, the test may be performed in max hold mode.

For an ESV operating in a continuous carrier mode, the measurement time shall be sufficient to ensure that at any frequency the difference between any two measurement results is less than 1 dB.

For an ESV operating in a non-continuous carrier mode, the average measurement shall be performed over the transmitted burst and the measurements from a series of bursts shall be combined as follows:

- Each measurement may exclude a specific portion of each burst. The excluded portion shall not exceed 50 μ s or 10 % of the burst, whichever is the smaller. The excluded portion shall be declared by the applicant.
- The measurements from several bursts shall be averaged to give a final measurement result. The number of bursts that are averaged shall be sufficient to ensure that the difference between any two final measurement results is less than 1 dB.
- c) The measurement shall be made in the operational configuration(s) (occupied bandwidth, EIRP_{nom}) producing the highest emission density in the frequency band. The selected configuration(s) shall be recorded in the test report.

6.5.1.3 Antenna transmit gain

6.5.1.3.1 General

For the purpose of the present document, the antenna transmit gain is defined as the ratio, expressed in decibels (dBi), of the power that would have to be supplied to the reference antenna, i.e. an isotropic radiator isolated in space, to the power supplied to the antenna being considered, so that they produce the same field strength at the same distance in the same direction. Unless otherwise specified the gain is for the direction of maximum radiation.

For the purpose of this test the EUT is defined as that part of the above-deck unit which comprises the antenna and its flange. The antenna includes the reflector(s), feed, support struts and an enclosure of equal weight/distribution to any electrical equipment normally housed with the feed at the antenna focal point.

6.5.1.3.2 Test site

This test shall be performed on either an outdoor far-field test site or compact test range. However if the near-field scanner technology to convert near-field measurements to far-field results is proven and sufficiently accurate by reference to tests taken in both regions then antenna measurements may be taken in the near field. Fully automated systems can be used for these tests providing that the results can be proven to be as accurate as if they were done according to the specified method.

6.5.1.3.3 Method of measurement

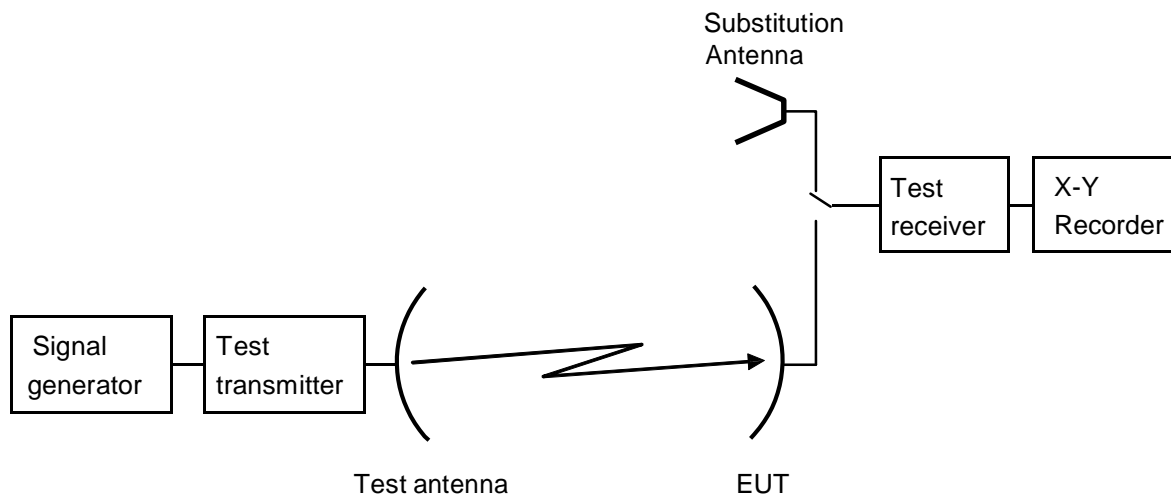

Figure 9: Test arrangement - antenna transmit gain measurement

- The test arrangement shall be as shown in figure 9 with the EUT connected to the test receiver. The test arrangement shall enable the test results to be displayed and recorded with the angular position along the X-axis and the signal level along the Y-axis.
- A test signal shall be transmitted by the test transmitter through the test antenna. The centre frequency of the test signal shall be set to the middle of the operating frequency band as declared by the applicant. The E-plane shall be vertical. The EUT antenna main beam axis shall be aligned with the main beam axis of the test transmitter. The polarizer of the EUT antenna shall be rotated and adjusted such that the E-plane coincides with the E-plane of the test transmitter.
- The EUT shall be aligned to maximize the received signal and the X-Y display adjusted to give the maximum reading on the plot.
- The EUT shall be driven in azimuth in one direction through 10 °.
- The pattern measurement is then obtained by driving the EUT in azimuth back through boresight to 10 ° the other side and recording the results.
- The EUT shall be replaced by the substitution antenna and the received signal level maximized.
- This level shall be recorded.
- The substitution antenna shall be driven in azimuth as in d) and e).
- The gain of the EUT shall be calculated from:

$$G_{\text{EUT}} = L_1 - L_2 + C$$

where:

- G_{EUT} is the gain of the EUT (dBi);
 - L_1 is the level obtained with the EUT (dB);
 - L_2 is the level obtained with the substitution antenna (dB);
 - C is the calibrated gain of the substituted antenna at the test frequency (dBi).
- The tests in c) to i) shall be repeated with the frequency changed to lowest carrier centre frequency of the operating frequency band as declared by the applicant.
 - The tests in c) to i) shall be repeated with the frequency changed to highest carrier centre frequency of the operating frequency band as declared by the applicant.

- l) The tests in b) to k) may be performed simultaneously.

6.5.1.4 Antenna transmit radiation patterns

6.5.1.4.1 General

For the purpose of the present document, the antenna transmit radiation patterns are diagrams relating field strength to the angle of the direction pointed by the antenna at a constant large distance from the antenna.

For the purpose of this test, the EUT is defined as that part of the above deck unit which comprises the antenna and its flange. The antenna includes the reflector(s), feed, support struts and an enclosure of equal weight/distribution to any electrical equipment normally housed with the feed at the antenna focal point.

6.5.1.4.2 Test site

This test shall be performed on either an outdoor far-field test site or compact test range. However, if the near-field scanner technology to convert near-field measurements to far-field results is proven and sufficiently accurate by reference to tests taken in both regions then antenna measurements may be taken in the near field. Fully automated systems can be used for these tests providing that the results can be proven to be as accurate as if they were done according to the specified method.

6.5.1.4.3 Test arrangement



Figure 10: Test arrangement - antenna transmit radiation pattern measurement

6.5.1.4.4 Co-polar radiation pattern-azimuth

- a) The test arrangement shall be as shown in figure 10 with the EUT connected to the test receiver. The test arrangement shall enable the test results to be displayed and recorded with the angular position along the X-axis and the signal level along the Y-axis.
- b) The frequency of the test signal shall be set to the middle frequency of the operating frequency band as declared by the applicant.
- c) The initial E-plane of the test signal radiated by the test transmitter through its antenna shall be vertical. The EUT antenna main beam axis shall be aligned with the main beam axis of the test transmitter. The polarizer of the EUT antenna shall be rotated and adjusted such that its E-plane coincides with the E-plane of the test transmitter. Precise co-polar peaking of the polarization shall be done by observing the cross-polar minimum (fine adjustment).
- d) The EUT shall be aligned to maximize the received signal and the X-Y display adjusted to give the maximum reading on the plot.
- e) The EUT shall be driven in azimuth to -180° .
- f) The transmit pattern measurement is then obtained by driving the EUT in azimuth from -180° to $+180^\circ$ with the results recorded.
- g) The tests in d) to f) shall be repeated with the frequency changed to the lowest carrier centre frequency of the operating frequency band as declared by the applicant.
- h) The tests in d) to f) shall be repeated with the frequency changed to the highest carrier centre frequency of the operating frequency band as declared by the applicant.
- i) The tests in b) to h) may be performed simultaneously.

- j) The tests in d) to i) shall be repeated with the E-plane of the test signal being horizontal. The frequency of the test signal shall be set to middle of the operating frequency band as declared by the applicant. The polarizer of the EUT antenna shall be rotated and adjusted such that its E-plane coincides with the E-plane of the test transmitter (giving the minimum cross-polar receive signal). Precise co-polar peaking of the polarization shall be done by observing the cross-polar minimum.

6.5.1.4.5 Co-polar radiation pattern-elevation

- a) The test arrangement shall be as shown in figure 10 with the EUT connected to the test receiver. The test arrangement shall enable the test results to be displayed and recorded with the angular position along the X-axis and the signal level along the Y-axis.
- b) The frequency of the test signal shall be set to the middle frequency of the operating frequency band as declared by the applicant.
- c) The initial E-plane of the test signal radiated by the test transmitter through its antenna shall be vertical. The EUT antenna main beam axis shall be aligned with the main beam axis of the test transmitter. The polarizer of the EUT antenna shall be rotated and adjusted such that its E-plane coincides with the E-plane of the test transmitter. Precise co-polar peaking of the polarization shall be done by observing the cross-polar minimum (fine adjustment).
- d) The EUT shall be aligned to maximize the received signal and the X-Y display adjusted to give the maximum reading on the plot.
- e) The EUT shall be driven in elevation to -1° .
- f) The transmit pattern measurement is then obtained by driving the EUT in elevation from -1° to 70° and the results recorded.
- g) The tests in d) to f) shall be repeated with the frequency changed to the lowest carrier centre frequency of the operating frequency band as declared by the applicant.
- h) The tests in d) to f) shall be repeated with the frequency changed to the highest carrier centre frequency of the operating frequency band as declared by the applicant.
- i) The tests in b) to h) may be performed simultaneously.
- j) The tests in d) to i) shall be repeated with the E-plane of the test signal being horizontal. The frequency of the test signal shall be set to the middle frequency of the operating frequency band as declared by the applicant. The polarizer of the EUT antenna shall be rotated and adjusted such that its E-plane coincides with the E-plane of the test transmitter. The EUT antenna main beam axis shall be aligned with the main beam axis of the test transmitter. Precise co-polar peaking of the polarization plane shall be done by observing the cross-polar minimum (fine adjustment).

6.5.1.4.6 Cross-polar radiation pattern-azimuth

- a) The test arrangement shall be as shown in figure 10 with the EUT connected to the test receiver. The test arrangement shall enable the test results to be displayed and recorded with the angular position along the X-axis and the signal level along the Y-axis.
- b) The frequency of the test signal shall be set to the middle frequency of the operating frequency band as declared by the applicant.
- c) The initial E-plane of the test signal radiated by the test transmitter through its antenna shall be vertical. The EUT antenna main beam axis shall be aligned with the main beam axis of the test transmitter. The polarizer of the EUT antenna shall be rotated and adjusted such that its E-plane is orthogonal to the E-plane of the test transmitter. Precise fine adjustment of the polarization plane shall be done by observing the cross-polar minimum.
- d) The boresight co-polar receive signal shall be used to adjust the X-Y display such that it gives the maximum reading on the plot.
- e) The EUT shall be driven in azimuth to -10° .

- f) The transmit pattern measurement is then obtained by driving the EUT in azimuth from -10° to $+10^\circ$ with the results recorded.
- g) The tests in d) to f) shall be repeated with the frequency changed to the lowest carrier centre frequency of the operating frequency band as declared by the applicant.
- h) The tests in d) to f) shall be repeated with the frequency changed to the highest carrier centre frequency of the operating frequency band as declared by the applicant.
- i) The tests in b) to h) may be performed simultaneously.
- j) The tests in d) to i) shall be repeated with the E-plane of the test signal being horizontal. The frequency of the test signal shall be set to the middle frequency of the operating frequency band as declared by the applicant. The EUT antenna main beam axis shall be aligned with the main beam axis of the test transmitter. The polarizer of the EUT antenna shall be rotated and adjusted such that its E-plane is orthogonal with the E-plane of the test transmitter precise fine adjustment of the polarization plane shall be done by observing the cross-polar minimum.

6.5.1.4.7 Cross-polar radiation pattern-elevation

- a) The test arrangement shall be as shown in figure 10 with the EUT connected to the test receiver. The test arrangement shall enable the test results to be displayed and recorded with the angular position along the X-axis and the signal level along the Y-axis.
- b) The frequency of the test signal shall be set to the middle frequency of the operating frequency band as declared by the applicant.
- c) The initial E-plane of the test signal radiated by the test transmitter through its antenna shall be vertical. The EUT antenna main beam axis shall be aligned with the main beam axis of the test transmitter. The polarizer of the EUT antenna shall be rotated and adjusted such that its E-plane is orthogonal to the E-plane of the test transmitter. Precise fine adjustment of the polarization plane shall be done by observing the cross-polar minimum.
- d) The boresight co-polar receive signal shall be used to adjust the X-Y display such that it gives the maximum reading on the plot.
- e) The EUT shall be driven in elevation to -1° .
- f) The transmit pattern measurement is then obtained by driving the EUT in elevation from -1° to $+10^\circ$ with the results recorded.
- g) The tests in d) to f) shall be repeated with the frequency changed to the lowest carrier centre frequency of the operating frequency band as declared by the applicant.
- h) The tests in d) to f) shall be repeated with the frequency changed to the highest carrier centre frequency of the operating frequency band as declared by the applicant.
- i) The tests in b) to h) may be performed simultaneously.
- j) The tests in d) to i) shall be repeated with the E-plane of the test signal being horizontal. The frequency of the test signal shall be set to the middle frequency of the operating frequency band as declared by the applicant. The EUT antenna main beam axis shall be aligned with the main beam axis of the test transmitter. The polarizer of the EUT antenna shall be rotated and adjusted such that its E-plane is orthogonal with the E-plane of the test transmitter precise fine adjustment of the polarization plane shall be done by observing the cross-polar minimum.

6.5.2 Computation of results

The results shall be computed by producing a "mask" to the specified limits with the reference level being equal to the sum of the transmitter output power density and the gain of the antenna. This reference shall then be placed on the maximum point of the plots obtained from the transmit radiation pattern measurements, so as to ascertain that the off-axis e.i.r.p. density is within the mask, and thus conforming to the specification in clause 4.2.4.

6.6 Carrier suppression

6.6.1 Test method

- For EUTs with antenna, the test arrangement for conducted measurements shall be as shown in figure 6. Otherwise, for EUTs without antenna, the test arrangement for radiated measurements shall be as shown in figure 7.
- The EUT shall transmit one modulated carrier continuously, or at its maximum burst rate where applicable, centred on the middle frequency of the operating frequency band as declared by the applicant.
- The resolution bandwidth of the spectrum analyser shall be set to 3 kHz.
- The "transmission disabled state" shall be obtained by use of the NCF.
- For conducted measurements the maximum residual carrier power density within the nominated bandwidth shall be measured and added to the antenna on-axis gain.
- For radiated measurements the maximum residual e.i.r.p. density within the nominated bandwidth shall be measured and recorded.

Instead of the NCF an STE provided by the applicant may be used to enable the ESV transmission to be suppressed.

6.7 Antenna pointing for ESV

6.7.1 General

The antenna pointing test method is designed to verify the ability of the EUT to detect and correctly respond to pointing errors that exceed the threshold, $\delta\varphi$, declared by the applicant as required in clauses 4.2.4 and 4.2.6. For the purposes of testing antenna pointing, the applicant shall declare:

- the operational dynamic limits for ship motion under which the ESV is expected to maintain tracking within the declared $\delta\varphi$;
- the survivability dynamic limits for operation without permanent damage; and
- the dynamic limits for testing of the EUT, which shall not be less than the operational dynamic limits and not greater than the survivability dynamic limits.

For the purpose of these tests the EUT is the ESV with its antenna connected.

6.7.2 Test method

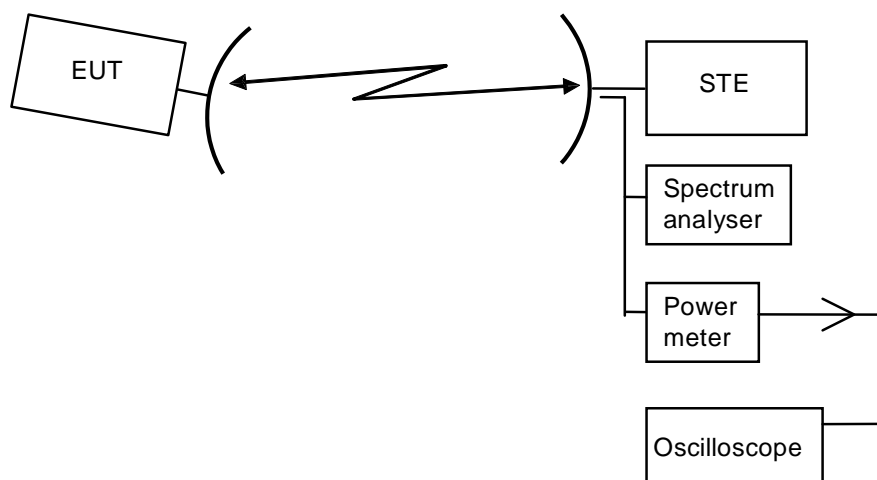

Figure 11: Test arrangement for pointing error detection

- a) The equipment shall be arranged as shown in figure 11. An actual satellite link may be used in place of the STE. In which case, care should be taken so that interference to adjacent satellites does not occur due to the pointing errors that will be induced in the test procedure (e.g. suppress the carrier or use a low e.i.r.p.).
- b) The signal received by the EUT shall be adjusted so that the signal to noise ratio corresponds to the minimum threshold signal to noise ratio declared by the applicant for reliable tracking.
- c) If the test is done with the carrier on then the spectrum analyser or the power meter shall be used to verify that the EUT has suppressed the carrier. Otherwise, the applicant shall describe how the tests are performed and it is determined that the carrier is suppressed.
- d) There shall be a means for measuring and analysing true pointing error values declared by the applicant. The means of measuring and analysing pointing errors shall be included in the test report.
- e) There shall be a means of dynamically inducing pointing errors that exceed the threshold declared by the applicant. The means for inducing pointing errors shall be representative of operating vessel dynamics, within the dynamic limits for testing the EUT, as declared by the applicant in clause 6.7.1. If dynamic means alone are not sufficient to induce pointing errors that exceed the threshold for pointing errors, then an alternative means shall be used. Pointing errors shall be induced in at least two orthogonal directions; but not necessarily during the same test sequence. The means of inducing pointing errors shall be included in the test report.
- f) Conduct of test:
 - 1) EUT shall be switched on and pointing towards the STE in a stable tracking state.
 - 2) Pointing errors of an increasing magnitude shall be induced in the EUT using the means given in e) above until the declared pointing error threshold is exceeded.
 - 3) It shall be verified that the EUT correctly detects that the induced pointing error has exceeded the pointing error threshold and enters the "Carrier-off" radio state no later than T seconds after the pointing error threshold is exceeded, where T is the response time declared by the applicant.
 - 4) Using the dynamic means given in e), the induced pointing error shall be decreased until it is less than the pointing error threshold.
 - 5) It shall be verified that the EUT does not re-enter the "Carrier-on" radio state for at least $2 \times T$ seconds.
- g) Step f) shall be repeated ten times.
- h) If the results in f) 3) are satisfied on all ten tests, then the EUT shall be declared compliant with the requirements

6.8 Antenna mechanical stability

6.8.1 Test method

As it is considered impracticable to perform a test on mechanical stability no test is given.

The methodology described in annex B shall be used to show compliance with the specification for mechanical stability.

6.9 Polarization angle alignment capability

6.9.1 Test method

The adjustment facilities shall be examined to determine both the angular movement possible and the means of establishing and fixing the alignment.

The applicant shall demonstrate by documentary evidence that the ESV complies with the specification c) in clause 4.2.6.2.

6.10 Cessation of emissions of the ESV

6.10.1 Test arrangement

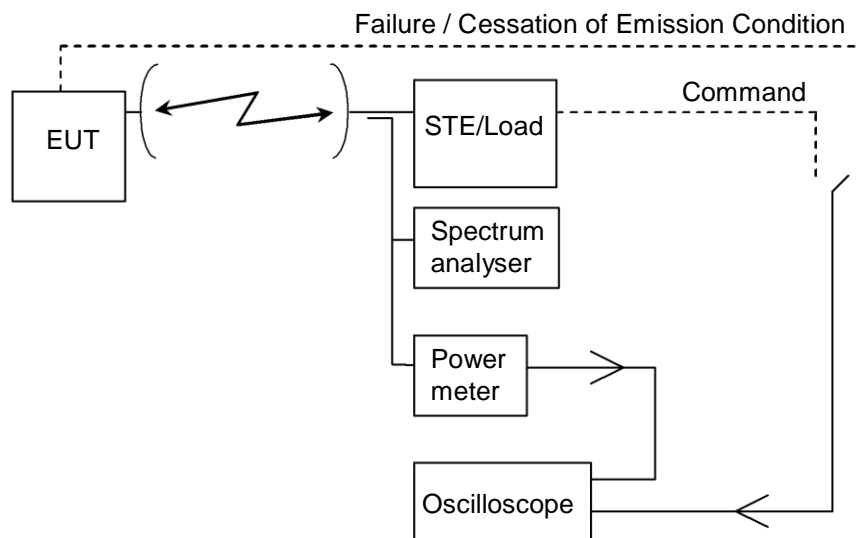

Figure 12: General test arrangement for control and monitoring tests for radiated measurements

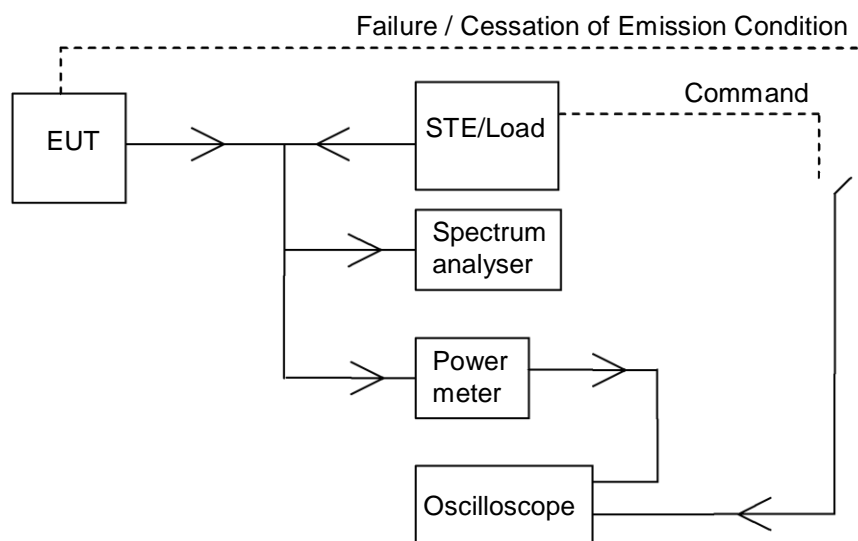

Figure 13: General test arrangement for control and monitoring tests for conducted measurements

The test arrangement shall be as shown in figure 12 or 13. There shall be a means of simulating a condition where cessation of emissions is required. The spectrum analyser or the oscilloscope shall be used to measure the time difference between the occurrence of the condition and the cessation of emissions. In all test methods, it shall be verified that the time difference does not exceed 5 seconds as specified in clause 4.2.7.2.3.

Where the EUT adds an operational margin around areas where cessation of emissions is required to account for the position determination accuracy and latency, the test procedure may simulate the actually behaviour of an EUT as it sails into an area where cessation of emissions is required. For example, if the EUT adds a margin of X meters around areas where cessation of emissions is required, then the test may begin with the EUT being simulated at a position more than X meters outside of an area where cessation of emissions is required. The test may then simulate the motion of the EUT towards the area where cessation of emissions is required. In any event, the EUT shall enter the "emission disabled" radio state within 5 seconds of entering the actual area where cessation of emissions is required.

For the purpose of these tests the EUT is the ESV either with, or without its antenna connected.

6.10.2 Test Method

6.10.2.1 Required documentation

The applicant shall declare the mode(s) of cessation of emissions implemented in the EUT and the ESV interfaces involved in the cessation of emissions as specified in clause 4.2.7.2.1.

The applicant shall demonstrate compliance with specification 2 in clause 4.2.7.2.2 for the determination of the conditions under which the ESV should cease emissions.

6.10.2.2 Cessation of emissions from the "Transmission enabled" state

- a) The EUT shall be set in the "Transmission enabled" ESV state.
- b) The EUT shall be set in the "Carrier on" radio state.
- c) A condition requiring the cessation of emission shall be initiated either by the STE or the EUT.
- d) It shall be verified that the EUT enters the "Emissions disabled" radio state.
- e) In order to verify that the EUT is in the "Transmission disabled" ESV state, it shall be verified that the EUT remains in the "Emissions disabled" radio state when the EUT is requested to transmit data.

6.10.2.3 Cessation of emission from the "Transmission disabled" state

- a) The EUT shall be set in the "Transmission disabled" state.
- b) A condition requiring the cessation of emission shall be initiated either by the STE or the EUT.
- c) In order to verify that the EUT remains in the "Transmission disabled" ESV state, it shall be verified that the EUT remains in the "Emissions disabled" radio state when the EUT is requested to transmit data.
- d) The STE shall send a TxE command to the EUT.
- e) In order to verify that the EUT remains in the "Transmission disabled" ESV state, it shall be verified that the EUT remains in the "Emissions disabled" radio state when the EUT is requested to transmit data.
- f) The STE shall send a TxD command to the EUT.
- g) The condition requiring the cessation of emissions shall be removed.
- h) In order to verify that the EUT remains in the "Transmission disabled" ESV state, it shall be verified that the EUT remains in the "Emissions disabled" radio state when the EUT is requested to transmit data.

6.10.2.4 Cessation of emission from the "Initial Phase" state

6.10.2.4.1 EUTs transmitting initial bursts

This applies only to EUTs transmitting initial bursts (i.e. where "Initial phase-1" and "Initial phase-2" are implemented).

- a) The EUT shall be set in "Initial phase-1" state.
- b) The STE shall not send the TxE command and the EUT shall be allowed to cycle between "Initial phase-1" and "Initial phase-2" as it would under normal operations.
- c) A condition requiring the cessation of emission shall be initiated either by the STE or the EUT.
- d) It shall be verified that the EUT enters the "Emissions disabled" radio state.
- e) In order to verify that the EUT is in the "Initial phase-0" ESV state, it shall be verified that the EUT remains in the "Emissions disabled" radio state when the EUT is requested to transmit data.
- f) The STE shall send a TxE command to the EUT.

- g) In order to verify that the EUT remains in the "Initial phase-0" ESV state or enters the "Transmission disabled" ESV state, it shall be verified that the EUT remains in the "Emissions disabled" radio state when the EUT is requested to transmit data.
- h) Repeat the test steps a) through g) using a TxD command in step f) instead of the TxE command.

6.10.2.4.2 EUTs not transmitting initial bursts

This applies only to EUTs that do not transmit initial bursts (i.e. where only "Initial phase-0" is implemented).

- a) The EUT shall be set in "Initial phase-0" ESV state.
- b) The STE shall not send the TxE command to maintain the EUT in "Initial phase-0" ESV state. c) A condition requiring the cessation of emission shall be initiated either by the STE or the EUT.
- d) In order to verify that the EUT remains in the "Initial phase-0" ESV state, it shall be verified that the EUT remains in the "Emissions disabled" radio state when the EUT is requested to transmit data.
- e) The STE shall send a TxE command to the EUT.
- f) In order to verify that the EUT remains in the "Initial phase-0" ESV state or enters the "Transmission disabled" ESV state, it shall be verified that the EUT remains in the "Emissions disabled" radio state when the EUT is requested to transmit data.
- g) Repeat the test steps a) through f) using a TxD command in step e) instead of the TxE command.

6.10.2.5 "Single action" means of cessation of emissions

- a) It shall be verified that there is a "single action" means of ceasing emissions on the below deck unit of the EUT.
- b) The EUT shall be set in the "Transmission enabled" ESV state.
- c) The EUT shall be set in the "Carrier on" radio state.
- d) The "single action" means of cessation of emissions shall be activated (e.g. the switch thrown).
- e) It shall be verified that the EUT enters the "Emissions disabled" radio state.
- f) In order to verify that the EUT is in the "Transmission disabled" ESV state, it shall be verified that the EUT remains in the "Emissions disabled" radio state when the EUT is requested to transmit data.
- g) The STE shall send a TxE command to the EUT.
- h) In order to verify that the EUT remains in the "Transmission disabled" ESV state, it shall be verified that the EUT remains in the "Emissions disabled" radio state when the EUT is requested to transmit data.
- i) The EUT shall be switched off and then switched on and the EUT shall enter the "Initial phase" ESV state without receiving a TxE from the STE.
- j) The "single action" means of cessation of emissions shall be activated.
- k) The STE shall send a TxE command to the EUT.
- l) In order to verify that the EUT remains in the "Initial phase" ESV state or enters the "Transmission disabled" ESV state, it shall be verified that the EUT remains in the "Emissions disabled" radio state when the EUT is requested to transmit data.
- m) The EUT shall be switched off and then switched on and the EUT shall enter the "Initial phase" ESV state without receiving a TxE from the STE.
- n) The STE shall send a TxD command to the EUT so that it enters the "Transmission disabled" ESV state.
- o) The "single action" means of cessation of emissions shall be activated.
- p) The STE shall send a TxE command to the EUT.

- q) In order to verify that the EUT remains in the "Transmission disabled" ESV state, it shall be verified that the EUT remains in the "Emissions disabled" radio state when the EUT is requested to transmit data.

6.10.2.6 Fault conditions

The applicant shall declare the means of generating fault conditions.

- a) The EUT shall be set in the "Transmission enabled" ESV state.
- b) The EUT shall be set in the "Carrier on" radio state.
- c) A fault condition requiring the cessation of emission shall be generated either by the STE or directly on the EUT.
- d) It shall be verified that the EUT enters the "Emissions disabled" radio state as long as the fault condition persists.
- e) Steps a) through d) shall be repeated for each fault condition declared by applicant.

6.11 Identification of ESV

6.11.1 Test arrangement

The test arrangement shall be as shown in figures 12 and 13. The test shall be arranged such that EUT can determine its own location, or if external means are employed, the test shall be arranged so that the EUT can be located by the means declared by the applicant. The STE shall be arranged to simulate the NCF. The actual location of the EUT shall be known within 100 m.

6.11.2 Test method

- a) The EUT shall be in the "Transmission enabled" state.
- b) The EUT shall report its location to the STE.
- c) The reported EUT location shall be within 1 km of the actual location of the EUT.

6.12 Control and monitoring functions

6.12.0 General

The applicant may modify an ESV for the purpose of these tests provided that full documentation is given to prove that the modifications accurately simulate the required test conditions.

The EUT shall transmit at $EIRP_{nom}$.

For the purpose of these tests the EUT is the ESV either with, or without its antenna connected.

The measurement of the e.i.r.p. spectral density shall be limited within either the nominated bandwidth or to a 10 MHz bandwidth centred on the carrier frequency, whichever is the greater.

6.12.1 Test arrangement

The test arrangement shall be as shown in figure 12 or 13. The EUT shall be authorized to transmit and shall be in the "Transmission enabled" state at the commencement of each test, unless otherwise stated. The dual trace storage oscilloscope shall monitor by measuring the time difference between the command, or failure, and the occurrence of the expected event (e.g. the transmission suppression). The spectrum analyser and the power meter shall monitor the EUT output level.

6.12.2 Processor monitoring- Test method

- a) Each of the processors within the EUT shall, in turn, be caused to fail.
- b) Within 5 seconds of such failure the EUT shall cease to transmit as measured by the oscilloscope.

- c) The power meter and spectrum analyser shall be observed to ascertain that the transmissions have been suppressed within the limits of the "Carrier-off" radio state emission levels.
- d) Within 30 seconds of such failure the power meter and spectrum analyser shall be observed to ascertain that the transmissions have been suppressed within the limits of the "Emissions disabled" radio state emission levels.
- e) The failed processor shall be restored to normal working condition and the EUT shall restore automatically to normal working before the next processor shall be induced to fail.

6.12.3 Transmit subsystem monitoring-Test method

To demonstrate compliance with clause 4.2.9.3.2, the following test procedure shall apply. However, for EUTs where it is not possible to directly induce failures in the components of the frequency generation subsystem, the applicant shall demonstrate compliance by documentary evidence.

- a) The frequency generation subsystem within the EUT shall be caused to fail in respect of:
 - 1) loss of frequency lock (if applicable);
 - 2) failure of the Local Oscillator (LO).
- b) Recognition of each failure in turn by the subsystem monitor shall constitute a SMF event.
- c) Within 5 seconds of such failure the EUT shall cease to transmit as measured by the oscilloscope.
- d) The power meter and spectrum analyser shall be observed to ascertain that the transmissions have been suppressed within the limits of the "Emissions disabled" radio state emission levels.
- e) The failed elements shall be restored to normal working state and the EUT shall be restored to normal working condition before the next induced failure.

6.12.4 Power-on/Reset-Test method

- a) The EUT shall be switched off and the STE shall not transmit the CC.
- b) The EUT shall be switched on.
- c) The EUT shall not transmit during and after switching-on, and shall enter the "Non valid" state.

The events from a) to c) shall be displayed and verified with the oscilloscope and by measurement of the transmitted signal. If a manual reset function is implemented the following test shall be performed:

- d) The EUT shall be restored to the "Initial phase" state and the STE shall transmit the CC.
- e) The EUT shall remain in the "Initial phase" state.
- f) The reset function shall be initiated.
- g) The EUT shall enter the "Non valid" state.
- h) The EUT shall be restored to the "Initial phase" state and the STE shall transmit the CC as well as a TxE. i) The EUT shall enter the "Transmission enabled" state.
- j) The reset function shall be initiated.
- k) The EUT shall enter the "Non valid" state.

The event from e) to h) shall be displayed and verified with the oscilloscope and by measurement of the transmitted signal.

6.12.5 Control Channel and Response Channel -Test method

Tests shall simulate the following events:

- The CC has never been received by the EUT after power-on.
- The CC is lost by the EUT after reception of a Transmission Enable command.
- The CC is lost by the EUT without reception of a Transmission Enable command.
- The CC is being lost by the EUT and a call is initiated within the Time-Out period T1.

The Time-Out period T1 used in the tests shall be 30 seconds.

- a) Case where the CC has never been received by the EUT after power-on:
 - a1) the EUT shall be switched off and the STE shall not transmit the CC;
 - a2) the EUT shall be switched on;
 - a3) the EUT shall remain in the "Non valid" state.

The events from a2) to a3) shall be displayed and verified with the oscilloscope and by measurement of the transmit signal.

- b) Case where the CC is lost by the EUT after reception of a Transmission Enable command:
 - b1) the EUT shall be switched-on and the STE shall transmit the CC and a TxE;
 - b2) the EUT shall enter the "Initial phase" state and go, if applicable, to the "Transmission enabled" state;
 - b3) a transmission request shall be initiated from the EUT;
 - b4) the STE shall stop transmitting the CC;
 - b5) within the period T1 from event b4), the EUT shall enter the "Non valid" state.

The events from b1) to b5) shall be displayed and verified with the oscilloscope and by measurement of the transmitted signal.

- c) Case where the CC is lost by the EUT without reception of a "Transmission enabled" state:
 - c1) the EUT shall be switched on and the STE shall transmit the CC;
 - c2) the EUT shall enter the "Initial phase" state;
 - c3) the STE shall stop transmitting the CC;
 - c4) the EUT shall enter in the "Non valid" state not later than T1;
 - c5) a transmission request shall be initiated and the EUT shall remain in the "Non valid" state.

The events from c2) to c5) shall be displayed and verified with the oscilloscope and by measurement of the transmitted signal.

- d) Case where the CC is being lost by the EUT and a call is initiated within the T1 period:
 - d1) the EUT shall be switched on and the STE shall transmit the CC;
 - d2) the STE shall stop transmitting the CC;
 - d3) within the period T1 from d2), a transmission request shall be initiated from the EUT;
 - d4) the EUT may transmit but within the T1 period the EUT shall enter the "Non valid" state.

The events from d2) to d4) shall be displayed and verified with the oscilloscope and by measurement of the transmitted signal.

6.12.6 Network Control commands-Test method

The following tests shall be performed in sequence:

- transmission enable command;
 - transmission disable command received in the "Transmission enabled" state;
 - transmission disable command received in the "Initial phase" state.
- a) Transmission enable command:
- a1) the EUT shall be switched-on and the STE shall transmit the CC;
 - a2) the EUT shall enter the "Initial phase" state;
 - a3) a transmission request shall be initiated from the EUT, the EUT shall remain in the "Initial phase" state;
 - a4) the STE shall transmit a transmit enable command to the EUT;
 - a5) a transmission request shall be initiated from the EUT;
 - a6) the EUT shall enter the "Transmission enabled" state and shall transmit.

The events from a2) to a6) shall be displayed and verified with the oscilloscope and by measurement of the transmitted signal.

- b) Transmission disable command received in the "Transmission enabled" state:
- b1) continue from a6);
 - b2) the STE shall transmit a disable command to the EUT;
 - b3) the EUT shall enter the "Transmission disabled" state within 1 second;
 - b4) a transmission request shall be initiated from the EUT;
 - b5) the EUT shall remain in the "Transmission disabled" state;
 - b6) the STE shall transmit an enable command;
 - b7) the EUT shall enter either the "Transmission enabled" state or the "Initial phase" state;
 - b8) if the EUT is in the "Transmission enable" state then the test continues with b11);
 - b9) the STE shall transmit a TxE command;
 - b10) the EUT shall enter the "Transmission enable" state;
 - b11) if a transmission request is not active any more than a new transmission request shall be initiated;
 - b12) the EUT shall transmit;
 - b13) the EUT transmission shall be terminated.

The events from b2) to b13) shall be displayed and verified with the oscilloscope and by measurement of the transmitted signal.

- c) Transmission disable command received in the "Initial phase" state:
- c1) the EUT shall be switched-on and the STE shall transmit the CC;
 - c2) the EUT shall enter the "Initial phase" state;
 - c3) the STE shall transmit a disable command to the EUT;
 - c4) the EUT shall enter the "Transmission disabled" state within 1 second;

- c5) a transmission request shall be initiated from the EUT;
- c6) the EUT shall remain in the "Transmission disabled" state;
- c7) the STE shall transmit an enable command;
- c8) the EUT shall enter either the "Transmission enabled" state or the "Initial phase" state;
- c9) if the EUT is in the "Transmission enable" state then the test continues with c12);
- c10) the STE shall transmit a TxE command;
- c11) the EUT shall enter the "Transmission enable" state;
- c12) if a transmission request is not active any more than a new transmission request shall be initiated;
- c13) the EUT shall transmit;
- c14) the EUT transmission shall be terminated.

The events from c2) to c14) shall be displayed and verified with the oscilloscope and by measurement of the transmitted signal.

6.12.7 Initial burst transmission-Test method

The applicant shall declare the initial burst duration.

The following test shall be performed in sequence:

- a) the EUT shall be switched-off and the STE shall transmit the CC;
- b) the EUT shall be switched-on;
- c) the EUT shall not transmit, except the initial bursts;
- d) it shall be verified that the specifications given in clause 4.2.9.7.2 are fulfilled.

The events from b) to d) shall be displayed and verified with the oscilloscope and by measurement of the transmitted signal.

6.13 Receive antenna off-axis gain pattern

6.13.1 Test Method

6.13.1.1 Test site

This test shall be performed on either an outdoor far field test site or compact test range. However if the near field scanner technology to convert near field measurements to far field results is proven and sufficiently accurate by reference to tests taken in both regions then antenna measurements may be taken in the near field. Fully automated systems can be used for these tests providing that the results can be proven to be as accurate as if they were done according to the specified method.

6.13.1.2 Method of measurement

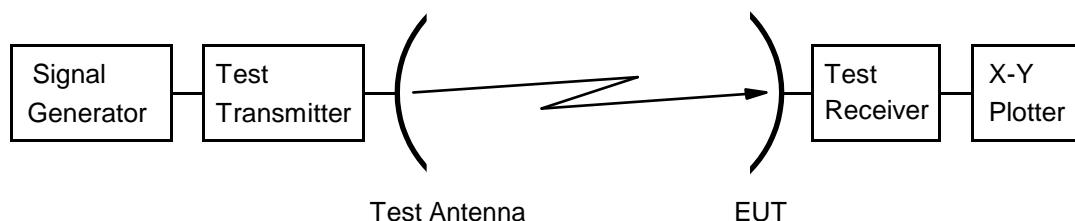

Figure 14: Test arrangement - antenna receive pattern measurement

- a) The test arrangement shall be as shown in figure 14 with the EUT connected to the test receiver.
- b) A signal proportional to the angular position from the servo mechanism shall be applied to the X-axis and the signal level from the test receiver shall be applied to the Y-axis of the plotter.
- c) The test frequencies shall be the centre frequency of each applicable frequency range. The E plane shall be vertical.
- d) The EUT shall be aligned to maximize the received signal level and the X-Y plotter shall be adjusted to give the maximum reading on the chart.
- e) The EUT shall be driven in azimuth through 180 °.
- f) The pattern measurement is then obtained by driving the EUT in azimuth through 360 ° with the plotter recording the results.
- g) The tests in b) to e) shall be repeated with the frequency changed to the lower limit of the applicable band as declared by the manufacturer.
- h) The tests in b) to e) shall be repeated with the frequency changed to the upper limit of the applicable band as declared by the manufacturer.
- i) The tests in b) to h) shall be repeated with the frequencies changed to the others specified if the design of the equipment is such that operation is possible, but not necessarily simultaneously, in all bands.
- j) The tests in b) to h) shall be repeated with the test signal being transmitted in the H-plane instead of the E-plane.
- k) The tests in b) to h) shall be repeated with the test signal being transmitted in a plane at 45 ° to the H-plane. l) The tests in b) to h) shall be repeated with the test signal being transmitted in a plane at 90 ° to that in k).
- m) The tests in b) to l) shall be repeated between the angles of ϕ_r and 7° with the EUT rotated through 90 °, or the test antenna or the polarization subsystem of the EUT rotated by 90 °, to give the cross-polar measurement.

6.14 Blocking performance

6.14.1 Test method

- a) The output signals of two signal generators shall be combined with equal weight. The combined signal shall be coupled to the LNB input in a reasonable and appropriate way.
- b) A spectrum analyser shall be connected to the LNB output in a way that allows to supply the LNB with power.
- c) is the center frequency of the receive frequency band.
- d) The first signal generator frequency shall be set to .
- e) The first signal generator level shall be set to a level in the LNB operational input level range.
- f) The spectrum analyser shall be set for measuring the level of the converted first signal at the LNB output.
- g) The second signal generator frequency shall be set to $- 20 \text{ MHz}$.
- h) The second signal generator level shall be adjusted so that the measured level is 1 dB less than in absence of the second signal.
- i) The second signal generator level shall be noted down as reference level.
- j) The second signal generator frequency shall be set to the frequency of interest.
- k) The second signal generator level shall be adjusted so that the measured level is 1 dB less than in absence of the second signal.
- l) The rejection at the frequency of interest is equal to the second signal generator level minus the reference level determined in step i).

m) Steps j) to l) shall be repeated for frequencies in the ranges of table 5.

NOTE: The worst case rejection in a particular frequency range can be determined after step i) by sweeping the second signal generator frequency over the frequency range and observe the gain compression, then perform steps j) to l) with the frequency where gain compression is highest.

6.15 Adjacent Signal Selectivity

6.15.1 Test method

- a) Two test signal generators shall be used. Each signal generator shall generate a modulated signal in the BDU input frequency range and thermal noise.
- b) The signal generators shall be connected to the BDU input through a splitter (combiner).
- c) The test signal generators shall be set to the frequencies and levels according to table 6. d)
The BDU shall be set to receive the signal of the first test signal generator.
- e) The second test signal generator shall be set to signal off.
- f) The noise level (or signal to noise ratio) of the first test signal generator shall be varied in order to determine the threshold reference sensitivity level.
- g) The second signal generator shall be set to signal on.
- h) The noise level (or signal to noise ratio) of the first test signal generator shall be varied in order to determine the threshold reference sensitivity level.
- i) The degradation is equal to the noise level (or signal to noise ratio) determined in step h minus that determined in step f.
- j) The result is the highest degradation found.

Annex A (normative): Relationship between the present document and the essential requirements of Directive 2014/53/EU

The present document has been prepared under the Commission's standardisation request C(2015) 5376 final [i.5] to provide one voluntary means of conforming to the essential requirements of Directive 2014/53/EU on the harmonisation of the laws of the Member States relating to the making available on the market of radio equipment and repealing Directive 1999/5/EC [9].

Once the present document is cited in the Official Journal of the European Union under that Directive, compliance with the normative clauses of the present document given in table A.1 confers, within the limits of the scope of the present document, a presumption of conformity with the corresponding essential requirements of that Directive, and associated EFTA regulations.

The present document is therefore intended to cover the provisions of Directive 2014/53/EU [9] (RE Directive) article 3.2 which states that "...radio equipment shall be so constructed that it both effectively uses and supports the efficient use of radio spectrum in order to avoid harmful interference".

Recital 10 of Directive 2014/53/EU [9] states that "*in order to ensure that radio equipment uses the radio spectrum effectively and supports the efficient use of radio spectrum, radio equipment should be constructed so that: in the case of a transmitter, when the transmitter is properly installed, maintained and used for its intended purpose it generates radio waves emissions that do not create harmful interference, while unwanted radio waves emissions generated by the transmitter (e.g. in adjacent channels) with a potential negative impact on the goals of radio spectrum policy should be limited to such a level that, according to the state of the art, harmful interference is avoided; and, in the case of a receiver, it has a level of performance that allows it to operate as intended and protects it against the risk of harmful interference, in particular from shared or adjacent channels, and, in so doing, supports improvements in the efficient use of shared or adjacent channels.*"

Recital 11 of Directive 2014/53/EU [9] states that "*although receivers do not themselves cause harmful interference, reception capabilities are an increasingly important factor in ensuring the efficient use of radio spectrum by way of an increased resilience of receivers against harmful interference and unwanted signals on the basis of the relevant essential requirements of Union harmonisation legislation*".

As a consequence, the present document includes both transmitting and receiving parameters to maximize the efficient use of radio spectrum.

**Table A.1: Relationship between the present document and
the essential requirements of Directive 2014/53/EU**

Harmonised Standard ETSI EN 302 340				
The following requirements are relevant to the presumption of conformity under the article 3.2 of Directive 2014/53/EU [9]				
Requirement			Requirement Conditionality	
No	Description	Reference: Clause No	U/C	Condition
1	Off-axis spurious radiation	4.2.1	U	
2	On-axis spurious radiation for ESV	4.2.2	U	
3	Maximum ESV emissions towards the horizon	4.2.3	U	
4	Off-axis e.i.r.p. emission density within the band	4.2.4	U	
5	Carrier suppression	4.2.5	U	
6	Antenna pointing and polarization alignment for ESVs	4.2.6	U	
7	Cessation of emissions of the ESV	4.2.7	U	
8	Identification of ESV	4.2.8	U	
9	CMF state diagram	4.2.9.1	U	
10	Processor monitoring	4.2.9.2	U	
11	Transmit subsystem monitoring	4.2.9.3	U	
12	Power on/Reset	4.2.9.4	U	
13	Control Channel (CC) and Response Channel (RC)	4.2.9.5	U	

Harmonised Standard ETSI EN 302 340				
The following requirements are relevant to the presumption of conformity under the article 3.2 of Directive 2014/53/EU [9]				
Requirement			Requirement Conditionality	
No	Description	Reference: Clause No	U/C	Condition
14	Network control commands	4.2.9.6	U	
15	Initial burst transmissions	4.2.9.7	U	
16	Receive antenna off-axis gain patterns	4.2.10	C	Satellite communications networks may contain a central control unit that keeps received interference low by taking into account the actual antenna gain pattern of earth stations. The requirement is not relevant for earth stations that are always operated as part of such a network. The requirement is relevant in all other cases. If the receive antenna performance does not meet the 4.2.10 requirement, then the earth station shall accept an additional co-frequency interference caused by its off-axis gain which is not compliant to the mask.
17	Blocking Performance	4.2.11	U	
18	Adjacent Signal Selectivity	4.2.12	U	

Key to columns:**Requirement:**

No A unique identifier for one row of the table which may be used to identify a requirement.

Description A textual reference to the requirement.

Clause Number Identification of clause(s) defining the requirement in the present document unless another document is referenced explicitly.

Requirement Conditionality:

U/C Indicates whether the requirement shall be unconditionally applicable (U) or is conditional upon the manufacturers claimed functionality of the equipment (C).

Condition Explains the conditions when the requirement shall or shall not be applicable for a requirement which is classified "conditional".

Presumption of conformity stays valid only as long as a reference to the present document is maintained in the list published in the Official Journal of the European Union. Users of the present document should consult frequently the latest list published in the Official Journal of the European Union.

Other Union legislation may be applicable to the product(s) falling within the scope of the present document.

Annex B (normative): Mechanical stability methodology

This test based on an analytical or numerical analysis shall be performed in two stages.

In the first stage the loads generated by the maximum wind speed shall be computed on the above deck unit, taking into account the intrinsic properties of the materials.

In the second stage the computed loads shall be applied to the structure.

The purpose of the analysis is twofold:

- a) To show that the torque and the fields of force applied to the above deck unit structure under nominated conditions do not reach any of the following:
 - the point where deformation fouls the antenna pointing mechanism;
 - the yield point of any element of the structure;
 - the buckling point of any element of the structure.

NOTE: The yield point is elastic limit of the material and the buckling point is the failure point for the material.

- b) To compute equivalent static loads (force and torque) applied to the critical attachment points of the structures, e.g.:
 - for antennas without a radome:
 - reflector-mounting legs fixing point;
 - reflector-struts;
 - LNB- struts;
 - for antennas with a radome:
 - radome surface;
 - radome mounting points.

Analysis and load applications procedure:

- a) The air related parameters, namely the kinetic viscosity used to calculate drags at the rims of the structure shall be calculated with the standard atmospheric environmental conditions (temperature = 293 K, air pressure = $1,013 \times 10^5$ Pascal).
- b) The computations needed to derive the field of force and torque and the equivalent static stresses shall be carried out for each of the following variables:
 - elevation angle: maximum and minimum for antennas without a radome;
 - wind direction: in steps of 45° around the above-deck unit;
 - wind speed: 100 km/h;
 - gust speed: 130 km/h for 3 seconds.
- c) It shall be verified with the simulated results that yield point limits are not exceeded for any self-contained element.
- d) The calculated equivalent static loads shall be applied at any identified critical fixing point of the assembly.
- e) Whilst the loads are applied the above deck unit shall be observed and any distortion noted.

- f) The test report shall contain the following information:
- the computation method used;
 - the description of the test equipment;
 - the description of the tests performed;
 - the results of the safety margin test;
 - any signs of distortion observed;
 - the results of the measurements of the deviation of the antenna or radome position;
 - the component deviation with respect to each other.

Annex C (informative): Bibliography

- ETSI ETR 169 (1995): "Satellite Earth Stations and Systems (SES); Common Technical Regulations (CTRs) in the satellite earth station equipment field".
- ETSI EN 301 843-6 (2005): "Electromagnetic compatibility and Radio spectrum Matters (ERM); ElectroMagnetic Compatibility (EMC) standard for marine radio equipment and services; Part 6: Specific conditions for Earth Stations on board Vessels, transmitting above 3 GHz".
- Directive 98/34/EC of the European Parliament and of the Council of 22 June 1998 laying down a procedure for the provision of information in the field of technical standards and regulations.
- Council Directive 73/23/EEC of 19 February 1973 on the harmonization of the laws of Member States relating to Electrical Equipment designed for use within certain voltage limits (LV Directive) as amended 93/68/EEC.
- Council Directive 89/336/EEC of 3 May 1989 on the approximation of the laws of the Member States relating to electromagnetic compatibility (EMC Directive).
- Directive 1999/5/EC of the European Parliament and of the Council of 9 March 1999 on radio equipment and telecommunications terminal equipment and the mutual recognition of their conformity (R&TTE Directive).

History

Document history		
V1.1.1	April 2006	Publication
V2.1.0	February 2016	EN Approval Procedure AP 20160515: 2016-02-15 to 2016-05-16
V2.1.1	May 2016	Publication